

Section 18

Contactors and Starters-IEC



TeSys D Contactors



TeSys F Contactors



TeSys GV3P



TeSys GV2P



TeSys U



TeSys H



TeSys U Self-Protected Combo Starter

Contactors and Overload Relays	18-2
TeSys™ K Contactors and Overload Relays	18-2
TeSys™ K Non-Reversing Mini-Contactors	18-2
TeSys™ K Overload Relays	18-3
TeSys™ K Reversing Mini-Contactors	18-4
TeSys™ D Contactors and Overload Relays	18-7
TeSys™ D Non-Reversing Contactors	18-8
TeSys™ D Overload Relays	18-9
TeSys™ D Reversing Contactors	18-10
TeSys™ D Capacitor Contactors	18-10
TeSys™ F Contactors and Overload Relays	18-11
TeSys™ F Non-Reversing Contactors	18-12
TeSys™ F Overload Relays	18-12
TeSys™ F Reversing Contactors	18-13
Contactor Accessories	18-14
TeSys™ K Contactors	18-14
TeSys™ D and F Contactors	18-15
TeSys™ D Contactors	18-17
TeSys™ F Contactors	18-20
Overload Relay Accessories	18-22
TeSys™ D and F Overload Relays	18-22
Motor Starters and Protectors	18-23
TeSys™ U Open Motor Starter	18-23
TeSys™ U Enclosed Combination Starters	18-27
TeSys™ H Ultra Compact Starters	18-32
TeSys™ GV Manual Starters and Protectors	18-33
PowerPact™ Manual Starters	18-34
TeSys™ D Enclosed Starters	18-38
TeSys™ D Enclosed Combination Starters	18-39
TeSys™ LS1 Fuse Holders	18-41
Soft Starter Module ATSU01	18-42
ATSU01 Altistart™ and TeSys™ U	18-42
Replacement Parts	18-43
TeSys™ D AC Coils	18-43
TeSys™ F AC Coils	18-45
TeSys™ D DC Coils	18-46
TeSys™ F DC Coils	18-47
TeSys™ F Contactors	18-48
Wiring Systems	18-49
Splitter Boxes, Power Connections, and Accessories	18-49
TeSys™ AK5 Panel Busbar System	18-50
Dimensions	18-51

TeSys™ K Non-Reversing Mini-Contactors



LC1K09

Table 18.1: AC Operating Coils

Maximum Horsepower Ratings						Maximum Current (A)		Continuous Current Rating (A)	Type of Connection	Auxiliary Contacts		Catalog Number ^{[1][2][3]} [4]
Single-Phase		Three-Phase				Inductive AC3	Resistive AC1			N.O.	N.C.	
115 V	230 V	200 V	230 V	460 V	575 V							
1/2	1	1.5	1.5	3	3	6	20	10	Screw-clamp	1	—	LC1K0610
										—	1	LC1K0601
1/2	1.5	2	3	5	5	9	20	20	Screw-clamp	1	—	LC1K0910
										—	1	LC1K0901
1	2	3	3	7.5	10	12	20	20	Screw-clamp	1	—	LC1K1210
										—	1	LC1K1201

Table 18.2: TeSys K Contactors with Spring Terminal Clamps^[5]

Maximum Horsepower Ratings						Maximum Current (A)		Continuous Current Ratings (A)	Catalog Number ^[1]
Single-Phase		Three-Phase				Inductive AC3	Resistive AC1		
115 V	230 V	200 V	230 V	460 V	575 V				
1/3	1	1.5	1.5	3	3	6	20	10	LC•K06••3
1/3	1.5	2	2	5	5	9	20	10	LC•K09••3
1/3	1.5	2	2	5	5	12	20	10	LC•K12••3

Table 18.3: Coil Voltage Codes for AC Contactors

Up to and including 240 V coil with integral suppression device available. Add 2 to the code required (for example, J72).

Vac 50/60 Hz	12	24	42	48	110	120	127	200/ 208	220/ 230	230	230/ 240	277	380/ 400	400/ 415	440	480	600
Code	J7	B7	D7	E7	F7	G7	FC7	L7	M7	P7	U7	UE7	Q7	N7	R7	T7	X7

Table 18.4: DC Operating Coils

Maximum Horsepower Ratings						Maximum Current (A)		Continuous Current Rating (A)	Type of Connection	Auxiliary Contacts		Catalog Number ^{[2][3][4][6]}
Single-Phase		Three-Phase				Inductive AC3	Resistive AC1			N.O.	N.C.	
115 V	230 V	200 V	230 V	460 V	575 V							
1/2	1	1.5	1.5	3	3	6	20	10	Screw-clamp	1	—	LP1K0610
										—	1	LP1K0601
1/2	1.5	2	3	5	5	9	20	20	Screw-clamp	1	—	LP1K0910
										—	1	LP1K0901
1	2	3	3	7.5	10	12	20	20	Screw-clamp	1	—	LP1K1210
										—	1	LP1K1201

Table 18.5: Coil Voltage Codes for DC Contactors

Coil with integral suppression device available. Add 3 to the code required (for example, JD3). [7]

Vdc	12	20	24	36	48	60	72	100	110	125	200	220	230	240	250
Code	JD	ZD	BD	CD	ED	ND	SD	KD	FD	GD	LD	MD	MPD	MUD	UD

[1] Complete the catalog number with the coil voltage code from Table 18.3 Coil Voltage Codes for AC Contactors, page 18-2 (for example, LC1K0610G7).
 [2] For spring terminal clamps, add a 3 before the coil voltage code (for example, LC2K06103G7). Spring terminal clamps reduce some of the HP and continuous current ratings of the TeSys K contactors. For ratings, please refer to Table 18.2 TeSys K Contactors with Spring Terminal Clamps, page 18-2.
 [3] For solder pin terminals, add a 5 before the coil voltage code (for example, LC1K09105B7).
 [4] For slip-on terminals, add a 7 before the coil voltage code (for example, LC1K12107M7).
 [5] Applies to all TeSys K contactors (LC1K, LC2K, LC7K, LC8K, LP1K, LC2K, LP4K and LP5K).
 [6] Complete the catalog number with the coil voltage code from Table 18.5 Coil Voltage Codes for DC Contactors, page 18-2 (for example, LP1K09004BD).
 [7] 3 W inrush.



LP4K09

Table 18.6: DC—Low Consumption Operating Coils (devices have built-in transient suppression)

Maximum Horsepower Ratings						Maximum Current (A)		Continuous Current Rating (A)	Type of Connection	Auxiliary Contacts		Catalog Number ^[8] / ^[9] / ^[10] / ^[11]
Single-Phase		Three-Phase				Inductive AC3	Resistive AC1			N.O.	N.C.	
115 V	230 V	200 V	230 V	460 V	575 V							
1/2	1	1.5	1.5	3	3	6	20	10	Screw-clamp	1	—	LP4K0610
										—	1	LP4K0601
										1	—	LP4K0910
1/2	1.5	2	3	5	5	9	20	20	Screw-clamp	—	1	LP4K0901
										1	—	LP4K1210
1	2	3	3	7.5	10	12	20	20	Screw-clamp	—	1	LP4K1201

Table 18.7: Coil Voltage Codes for DC Contactors—Low Consumption ^[12]

Vdc Code	12	24	48	72
	JW3	BW3	EW3	SW3

TeSys™ K Overload Relays

Table 18.8: Overload Relays for 3-Pole Contactors with Screw-Clamp Terminals



LR2K0316

Current Setting Range (A)	Catalog Number	
0.11 to 0.16	LR2K0301	LR2K overload relays <ul style="list-style-type: none"> • AC or DC protection • Ambient compensated bimetallic • Class 10 • Single phase sensitivity • Manual or auto reset • Full load current dial
0.16 to 0.23	LR2K0302	
0.23 to 0.36	LR2K0303	
0.36 to 0.54	LR2K0304	
0.54 to 0.8	LR2K0305	
0.8 to 1.2	LR2K0306	
1.2 to 1.8	LR2K0307	
1.8 to 2.6	LR2K0308	
2.6 to 3.7	LR2K0310	
3.7 to 5.5	LR2K0312	
5.5 to 8	LR2K0314	
8 to 11.5	LR2K0316	
10 to 14	LR2K0321 ^[13]	

Accessories: TeSys™ K Contactors and Accessories, page 18-14
Dimensions: TeSys K Contactor Dimensions, page 18-63



E164862

CCN NLDX

(screw terminals)



LR43364

Class 3211 04



E164862

CCN NLDX2

(slip-on and solder-pin terminals)



[8] Complete the catalog number with the coil voltage code from Table 18.7 Coil Voltage Codes for DC Contactors—Low Consumption, page 18-3 (for example, LC2K0610BD).

[9] For spring terminal clamps, add a 3 before the coil voltage code (for example, LC2K06103G7). Spring terminal clamps reduce some of the HP and continuous current ratings of the TeSys K contactors. For ratings, please refer to Table 18.2 TeSys K Contactors with Spring Terminal Clamps, page 18-2.

[10] For solder pin terminals, add a 5 before the coil voltage code (for example, LP1K09105BW3).

[11] For slip-on terminals, add a 7 before the coil voltage code (for example, LP1K12107BW3).

[12] 1.8 W inrush.

[13] Not UL Listed.

TeSys™ K Reversing Mini-Contactors

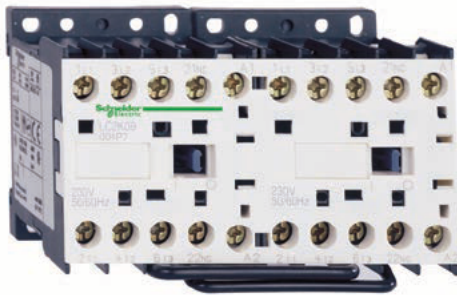

LC2K0910

Table 18.9: AC Operating Coils

Maximum Horsepower Ratings						Maximum Current (A)		Continuous Current Rating (A)	Type of Connection	Auxiliary Contacts		Catalog Number ^[14] ^{[15][16][17]}
Single-Phase		Three-Phase				Inductive AC3	Resistive AC1			N.O.	N.C.	
115 V	230 V	200 V	230 V	460 V	575 V							
1/2	1	1.5	1.5	3	3	6	20	10	Screw-clamp	1	—	LC2K0610
										—	1	LC2K0601
1/2	1.5	2	3	5	5	9	20	20	Screw-clamp	1	—	LC2K0910
										—	1	LC2K0901
1	2	3	3	7.5	10	12	20	20	Screw-clamp	1	—	LC2K1210
										—	1	LC2K1201

Table 18.10: Coil Voltage Codes for AC Contactors

Up to and including 240 V coil with integral suppression device available. Add 2 to the code required. Example: J72.

Vac 50/60 Hz	12	24	42	48	110	120	127	200/ 208	220/ 230	230	230/ 240	277	380/ 400	400/ 415	440	480	600
Code	J7	B7	D7	E7	F7	G7	FC7	L7	M7	P7	U7	UE7	Q7	N7	R7	T7	X7

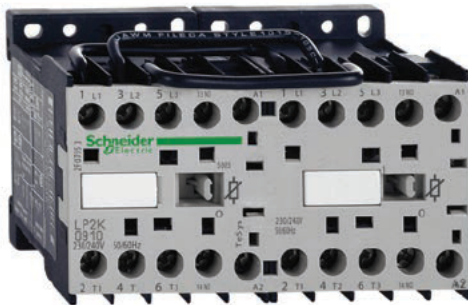

LP2K0910

Table 18.11: DC Operating Coils

Maximum Horsepower Ratings						Maximum Current (A)		Continuous Current Rating (A)	Type of Connection	Auxiliary Contacts		Catalog Number ^{[15][16][17][18]}
Single-Phase		Three-Phase				Inductive AC3	Resistive AC1			N.O.	N.C.	
115 V	230 V	200 V	230 V	460 V	575 V							
1/2	1	1.5	1.5	3	3	6	20	10	Screw-clamp	1	—	LP2K0610
										—	1	LP2K0601
1/2	1.5	2	3	5	5	9	20	20	Screw-clamp	1	—	LP2K0910
										—	1	LP2K0901
1	2	3	3	7.5	10	12	20	20	Screw-clamp	1	—	LP2K1210
										—	1	LP2K1201

Table 18.12: Coil Voltage Codes for DC Contactors

Coil with integral suppression device available. Add 3 to the code required. Example: JD3. ^[19]

Vdc	12	20	24	36	48	60	72	100	110	125	200	220	230	240	250
Code	JD	ZD	BD	CD	ED	ND	SD	KD	FD	GD	LD	MD	MPD	MUD	UD

[14] Complete the catalog number with the coil voltage code from Table 18.10 Coil Voltage Codes for AC Contactors, page 18-4 (for example, LC2K0610G7).
 [15] For spring terminal clamps, add a 3 before the coil voltage code (for example, LC2K06103G7). Spring terminal clamps reduce some of the HP and continuous current ratings of the TeSys K contactors. For ratings, please refer to TeSys K Contactors with Spring Terminal Clamps, page 18-2.
 [16] For solder pin terminals, add a 5 before the coil voltage code (for example, LC2K09105B7).
 [17] For slip-on terminals, add a 7 before the coil voltage code (for example, LC2K12107M7).
 [18] Complete the catalog number with the coil voltage code from Table 18.12 Coil Voltage Codes for DC Contactors, page 18-4 (for example, LC2K0610BD).
 [19] 3 W inrush.

Table 18.13: DC—Low Consumption Operating Coils (devices have built-in transient suppression)

Maximum Horsepower Ratings						Maximum Current (A)		Continuous Current Rating (A)	Type of Connection	Auxiliary Contacts		Catalog Number ^[20] [21][22][23]
Single-Phase		Three-Phase				Inductive AC3	Resistive AC1			N.O.	N.C.	
115 V	230 V	200 V	230 V	460 V	575 V							
1/2	1	1.5	1.5	3	3	6	20	10	Screw-clamp	1	—	LP5K0610
										—	1	LP5K0601
1/2	1.5	2	3	5	5	9	20	20	Screw-clamp	1	—	LP5K0910
										—	1	LP5K0901
1	2	3	3	7.5	10	12	20	20	Screw-clamp	1	—	LP5K1210
										—	1	LP5K1201

Table 18.14: Coil Voltage Codes for DC Contactors—Low Consumption^[24]

Vdc Code	12	24	48	72
	JW3	BW3	EW3	SW3



LC2K090045

Table 18.15: AC Operating Coils

Maximum Horsepower Ratings						Maximum Current (A)		Continuous Current Rating (A)	Type of Connection	Power Poles		Catalog Number ^[25] ^[26] ^[27] [28]
Single-Phase		Three-Phase				Inductive AC3	Resistive AC1			N.O.	N.C.	
115 V	230 V	200 V	230 V	460 V	575 V							
4-Pole Mini Contactor												
1/2	1.5	2	3	5	5	9	20	20	Screw-clamp	4	—	LC1K09004
1	2	3	3	7.5	10	12	20	20	Screw-clamp	2	2	LC1K09008
										4	—	LC1K12004
4-Pole Mechanically Interlocked Contactors												
1/2	1.5	2	3	5	5	9	20	20	Screw-clamp	4	—	LC2K09004
1	2	3	3	7.5	10	12	20	20	Screw-clamp	4	—	LC2K12004

Table 18.16: Coil Voltage Codes for AC Contactors

Up to and including 240 V coil with integral suppression device available. Add 2 to the code required. Example: J72.

Vac 50/60 Hz Code	12	24	42	48	110	120	127	200/208	220/230	230	230/240	277	380/400	400/415	440	480	660/690
	J7	B7	D7	E7	F7	G7	FC7	L7	M7	P7	U7	UE7	Q7	N7	R7	T7	Y7

Table 18.17: DC Operating Coils

Maximum Horsepower Ratings						Maximum Current (A)		Continuous Current Rating (A)	Type of Connection	Power Poles		Catalog Number ^[29] ^[26] ^[27] [28]
Single-Phase		Three-Phase				Inductive AC3	Resistive AC1			N.O.	N.C.	
115 V	230 V	200 V	230 V	460 V	575 V							
4-Pole Mini Contactor												
1/2	1.5	2	3	5	5	9	20	20	Screw-clamp	4	—	LP1K09004
1	2	3	3	7.5	10	12	20	20	Screw-clamp	2	2	LP1K09008
										4	—	LP1K12004
4-Pole Mechanically Interlocked Contactors												
1/2	1.5	2	3	5	5	9	20	20	Screw-clamp	4	—	LP2K09004
1	2	3	3	7.5	10	12	20	20	Screw-clamp	4	—	LP2K12004

Table 18.18: Coil Voltage Codes for DC Contactors

Coil with integral suppression device available. Add 3 to the code required. Example: JD3^[30]

Vdc Code	12	20	24	36	48	60	72	100	110	125	200	220	230	240	250
	JD	ZD	BD	CD	ED	ND	SD	KD	FD	GD	LD	MD	MPD	MUD	UD

Overload Relays: 3-Pole Reversing Mini-Contactors, page 18-4
Accessories: TeSys K Contactors and Accessories, page 18-14
Dimensions: TeSys K Contactor Dimensions, page 18-63

[20] Complete the catalog number with the coil voltage code from Table 18.14 Coil Voltage Codes for DC Contactors—Low Consumption, page 18-5 (for example, LP4K09004BW3).
[21] For spring terminal clamps, add a 3 before the coil voltage code (for example, LC2K06103G7). Spring terminal clamps reduce some of the HP and continuous current ratings of the TeSys K contactors. For ratings, please refer to TeSys K Contactors with Spring Terminal Clamps, page 18-2.
[22] For solder pin terminals, add a 5 before the coil voltage code (for example, LC1K090045B7).
[23] For slip-on terminals, add a 7 before the coil voltage code (for example, LC1K120047M7).
[24] 1.8 W inrush.
[25] Complete the catalog number with the coil voltage code from Table 18.16 Coil Voltage Codes for AC Contactors, page 18-5 (for example, LC1K09004G7).
[26] For spring terminal clamps, add a 3 before the coil voltage code (for example, LC2K06103G7). Spring terminal clamps reduce some of the HP and continuous current ratings of the TeSys K contactors. For ratings, please refer to TeSys K Contactors with Spring Terminal Clamps, page 18-2.
[27] For solder pin terminals, add a 5 before the coil voltage code (for example, LC1K090045B7).
[28] For slip-on terminals, add a 7 before the coil voltage code (for example, LC1K120047M7).
[29] Complete the catalog number with the coil voltage code from Table 18.18 Coil Voltage Codes for DC Contactors, page 18-5 (for example, LP2K09004BD).
[30] 3 W inrush.

Table 18.19: DC—Low Consumption Operating Coils (devices have built-in transient suppression)

Maximum Horsepower Ratings						Maximum Current (A)		Continuous Current Rating (A)	Type of Connection	Power Poles		Catalog Number ^{[31][32][33][34]}
Single-Phase		Three-Phase				Inductive AC3	Resistive AC1			N.O.	N.C.	
115 V	230 V	200 V	230 V	460 V	575 V							
4-Pole Mini Contactor												
1/2	15	2	3	5	5	9	20	20	Screw-clamp	4	—	LP4K09004
1	2	3	3	7.5	10	12	20	20	Screw-clamp	2	2	LP4K09008
4-Pole Mechanically Interlocked Contactors												
1/2	15	2	3	5	5	9	20	20	Screw-clamp	4	—	LP5K09004
1	2	3	3	7.5	10	12	20	20	Screw-clamp	4	—	LP5K12004

Table 18.20: Coil Voltages for DC Contactors—Low Consumption^[35]

Vdc Code	12	24	48	72
	JW3	BW3	EW3	SW3

Overload Relays: TeSys™ K Reversing Mini-Contactors, page 18-4
 Accessories: TeSys K Contactors and Accessories, page 18-14
 Dimensions: TeSys K Contactor Dimensions, page 18-53

[31] Complete the catalog number with the coil voltage code from Table 18.20 Coil Voltages for DC Contactors—Low Consumption, page 18-6 (for example, LP4K09004BW3).
 [32] For spring terminal clamps, add a 3 before the coil voltage code (for example, LC2K06103G7). Spring terminal clamps reduce some of the HP and continuous current ratings of the TeSys K contactors. For ratings, please refer to TeSys K Contactors with Spring Terminal Clamps, page 18-2.
 [33] For solder pin terminals, add a 5 before the coil voltage code (for example, LP4K090045BW3).
 [34] For slip-on terminals, add a 7 before the coil voltage code (for example, LP4K120047M7).
 [35] 1.8 W inrush.

TeSys™ D Catalog Number Interpretation

Table 18.21: TeSys D Contactors—Interpretation of the Catalog Number^[36]

LC		D		A		
Full Voltage, Non-Reversing	1					
Full Voltage, Reversing	2					
TeSys D 3 Pole Contactors, 9–150 A						
Contactor AC-3 Full Load Amperes (FLA)						
9 A FLA			09			
12 A FLA			12			
18 A FLA			18			
25 A FLA			25			
32 A FLA			32			
38 A FLA			38			
40 A FLA			40			
50 A FLA			50			
65 A FLA			65			
80 A FLA			80			
95 A FLA			95			
115 A FLA			115			
150 A FLA			150			
Everlink Power Connection (40–65 A only)				A		
No Everlink Power Connection (9–38 A, 80–150 A)				Blank		
Termination Options (choose one)						
Screw Termination				Blank		
Spring Terminations ^[37]				3		
Ring Tongue Terminations ^[38]				6		
Slip-on Terminations (9–12 A only)				9		
Coil Voltage (choose one)						
AC Coils (50/60 Hz)		DC Low Consumption Coils 9–38 A only		AC/DC Electronic Coils 9–38 A, 40–65 A Everlink only		
Voltage	Coil Code	Voltage	Coil Code	Voltage	Coil Code	
12 V	J7	5 V	AL	24–60 V	BNE	
21 V	Z7	12 V	JL	48–130 V	EHE	
24 V	B7	21 V	ZL	100–250 V	KUE	
36 V	C7	24 V	BL	250–415 Vac	USE ^[39]	
42 V	D7	48 V	EL	250–500 Vdc		
48 V	E7	72 V	SL			
60 V	EE7	96 V	DL			
100 V	K7	110 V	FL			
110 V	F7	220 V	ML			
115 V	FE7	250 V	UL			
120 V	G7					
127 V	FC7	DC Electronic Low Consumption Coils 40–65 A Everlink only				
200 V	L7	Voltage	Coil Code			
208 V	LE7	24 V	BBE			
220 V	M7					
230 V	P7					
240 V	U7					
277 V	W7					
380 V	Q7					
400 V	V7					
415 V	N7					
440 V	R7					
480 V	T7					
500 V	S7					
575 V	SC7					
600 V	X7					
660 V	Y5 (50 Hz only)					
					DC Coils (Standard)	
					Voltage	Coil Code
					12 V	JD
					21 V	ZD
					24 V	BD
					36 V	CD
					48 V	ED
					60 V	ND
					72 V	SD
					110 V	FD
					125 V	GD
					220 V	MD
					250 V	UD
					440 V	RD

^[36] Use this table only to interpret current catalog numbers. Some combinations are not available.

^[37] For spring terminal versions of LC1D09–LC1D65A, add 3 to the catalog number prior to adding the voltage code (for example, LC1D12G7 becomes LC1D123G7, and LC1D40AG7 becomes LC1D40A3G7. Note that 40–65 A spring terminals are only on the control terminations and not on power terminations).

^[38] For ring tongue versions of LC1D09–LC1D65A and LC1DT20–LC1DT80A, add 6 to the catalog number prior to adding the voltage code (for example, LC1D09G7 becomes LC1D096G7, and LC1D50AG7 becomes LC1D50A6G7).

^[39] Available in 2018.

TeSys™ D Non-Reversing Contactors



Table 18.22: TeSys D Contactors—3 or 4 Pole, Screw Terminal Connections

Maximum Horsepower Ratings						Maximum Current (A)		Continuous Current Rating (A)	No. of Poles		Instantaneous Auxiliary Contacts		Catalog Number [40]
Single-Phase		Three-Phase				Inductive AC3	Resistive AC1		N.O.	N.C.	N.O.	N.C.	
115 V	230 V	200 V	230 V	460 V	575 V								
1/3	1	2	2	5	7.5	9	20	25	3	0	1	1	LC1D09 [41][42][43]
—	—	—	—	—	—	—			4	2			LC1DT20 [41]
—	—	—	—	—	—	—	25	25	2	2	1	1	LC1D098 [41]
1/2	2	3	3	7.5	10	12			3	0			LC1D12 [41][42][43]
—	—	—	—	—	—	—	32	32	4	2	1	1	LC1DT25 [41]
—	—	—	—	—	—	—			2	2			LC1D128 [41]
1	3	5	5	10	15	18	40	40	3	0	1	1	LC1D18 [41][42]
—	—	—	—	—	—	—			4	2			LC1DT32 [41]
—	—	—	—	—	—	—	50	50	2	2	1	1	LC1D188 [41]
2	3	7.5	7.5	15	20	25			3	0			LC1D25 [41][41]
—	—	—	—	—	—	—	60	60	4	2	1	1	LC1DT40 [41]
—	—	—	—	—	—	—			2	2			LC1D258 [41]
2	5	10	10	20	25	32	80	80	3	0	1	1	LC1D32 [41][42]
2	5	10	10	20	25	38			3	0			LC1D38 [41][42]
—	—	—	—	—	—	—	125	110	3	0	1	1	LC1D40A [41]
3	5	10	10	30	30	40			4	0			LC1D60A [41]
—	—	—	—	—	—	—	200	160	3	0	1	1	LC1D50A [41]
3	7.5	15	15	40	40	50			3	0			LC1D65A [41]
—	—	—	—	—	—	—	125	110	4	0	0	0	LC1D80A [41]
—	—	—	—	—	—	—			3	0			LC1D80
7.5	15	25	30	60	60	80	200	160	4	0	0	0	LC1D80004 [44]
—	—	—	—	—	—	—			2	2			LC1D80008 [44]
—	—	—	—	—	—	—	200	160	3	0	1	1	LC1D95
7.5	15	25	30	60	60	95			3	0			LC1D115
—	—	—	—	—	—	—	200	160	3	0	1	1	LC1D150
—	—	—	—	—	—	—			4	0			LC1D115004

Table 18.23: TeSys D Coil Voltage Codes [45]

Contactor	Hz	24 V	48 V	110 V	120 V	125 V	208 V	220 V	240 V	250 V	440 V	480 V	600 V
AC													
D09–D150	50/60	B7	E7	F7	G7	—	LE7	M7	U7	—	—	T7 [46]	X7 [46]
LC1D80–LC1D150	50	B5	E5	F5	—	—	—	M5 [46]	U5	—	—	—	—
	60	B6	E6	F6	G6	—	L6	M6	U6	—	—	T6	X6 [46]
DC													
D09–D38, DT20–D258 Low Consumption	—	BL	EL	FL	—	—	—	ML	—	UL	—	—	—
D09–D150	—	BD	ED	FD	—	GD	—	MD	—	UD	RD	—	—

[40] Complete the catalog number by adding the coil voltage code from Table 18.23 TeSys D Coil Voltage Codes, page 18-8 for example, LC1D09G7.
 [41] For ring tongue versions of LC1D09–LC1D65A and LC1DT20–LC1DT80A, add 6 to the catalog number prior to adding the voltage code (for example, LC1D09G7 becomes LC1D096G7 and LC1D50AG7 becomes LC1D50A6G7).
 [42] For spring terminals versions of LC1D09–LC1D65A, add 3 to the catalog number prior to adding the voltage code (for example, LC1D12G7 becomes LC1D123G7 and LC1D40AG7 becomes LC1D40A3G7. Note that 40–65 A spring terminals are only on the control terminations and not on power terminations).
 [43] For slip-on connector versions of LC1D09 and LC1D12 only, add 9 to the catalog number prior to adding the voltage code (for example, LC1D09G7 becomes LC1D099G7).
 [44] For DC version of these devices, replace the C with a P (for example, LC1D80004** becomes LP1D80004**). This applies only to 80 A, 4-pole devices.
 [45] For additional voltage codes refer to the Control and Protection Components Catalog MKTED210011EN.
 [46] Not available for LC1D80–LC1D150.

TeSys™ D Overload Relays

Table 18.24: TeSys D Overload Relays—Ambient Compensated, Bimetallic, Direct Mounting

Current Setting Range (A)	For Direct Mounting to LC1D/LC2D...	Class 10 with Single-Phase Sensitivity	Class 10 without Single-Phase Sensitivity	Class 20 with Single-Phase Sensitivity	Class 20 without Single-Phase Sensitivity
0.10–0.16	D09–D38	LRD01	LR3D01	—	—
0.16–0.25		LRD02	LR3D02	—	—
0.25–0.40		LRD03	LR3D03	—	—
0.40–0.63		LRD04	LR3D04	LRD04L	LR3D04L
0.63–1		LRD05	LR3D05	LRD05L	LR3D05L
1–1.6		LRD06	LR3D06	LRD06L	LR3D06L
1.6–2.5		LRD07	LR3D07	LRD07L	LR3D07L
2.5–4		LRD08	LR3D08	LRD08L	LR3D08L
4–6		LRD10	LR3D10	LRD10L	LR3D10L
5.5–8		LRD12	LR3D12	LRD12L	LR3D12L
7–10	LRD14	LR3D14	LRD14L	LR3D14L	
9–13	D12–D38	LRD16	LR3D16	LRD16L	LR3D21L
12–18	D18–D38	LRD21	LR3D21	LRD21L	LR3D21L
16–24		LRD22	LR3D22	—	—
17–24		—	—	LRD22L	LR3D22L
23–32	D25–D38	LRD32	LR3D32	LRD32L	LR3D32L
30–38	D32–D38	LRD35	LR3D35	—	—
9–13	D40A–D65A	LRD313	LR3D313	LRD313L	—
12–18	D40A–D65A	LRD318	LR3D318	LRD318L	—
17–25	D40A–D65A	LRD325	LR3D325	LRD325L	—
23–32	D40A–D65A	LRD332	LR3D332	LRD332L	—
30–40	D40A–D65A	LRD340	LR3D340	LRD340L	—
37–50	D40A–D65A	LRD350	LR3D350	LRD350L	—
48–65	D40A–D65A	LRD365	LR3D365	LRD365L	—
17–25	D40–D95	LRD3322	LR3D3322	LRD23522	LR3D3522
23–32	D40–D95[47]	LRD3353	LR3D3353	LRD23553	LR3D3553
30–40	D40–D95[47]	LRD3355	LR3D3355	LRD23555	LR3D3555
37–50	D50–D95[47]	LRD3357	LR3D3357	LRD23557	LR3D3557
48–65	D50–D95[47]	LRD3359	LR3D3359	LRD23559	LR3D3559
55–70	D65–D95	LRD3361	LR3D3361	LRD23561	LR3D3561
63–80	D65–D95	LRD3363	LR3D3363	LRD23563	LR3D3563
80–104	D95	LRD3365	—	—	—
80–104	D115–D150	LRD4365	—	—	—
95–120	D115–D150	LRD4367	—	—	—
110–140	D150	LRD4369	—	—	—

Table 18.25: TeSys LR9D Electronic Overload Relays ^{New!}

Current Setting Range (A)	For Direct Mounting Beneath Contactor LC1D/LC2D	Class 5/10/20/30 Selectable
0.1–0.5	D09–D38	LR9D01
0.4–2	D09–D38	LR9D02
1.6–8	D09–D38	LR9D08
6.4–32	D09–D38	LR9D32
22–110	N/A (Separate Mounting Only)	LR9D110S

Table 18.26: TeSys D Overload Relays—Solid State

Current Setting Range (A)	For Direct Mounting Beneath Contactor LC1	Class 10	Class 20	Class 10/20 Selectable
60–100	D115–D150	LR9D5367	LR9D5567	LR9D67
90–150	D115–D150	LR9D5369	LR9D5569	LR9D69

TeSys D contactor accessories: TeSys™ D & F Auxiliary Contacts, Time Delay, Mechanical Latch, page 18-15
 TeSys D overload relay accessories: TeSys D Overload Relay Accessories, page 18-22
 TeSys D replacement coils: TeSys™ D AC Coils, page 18-43
 Dimensions: TeSys™ D Contactors, AC and DC Coil, page 18-51 to TeSys™ D Thermal Overload Relay Dimensions, page 18-59
 TeSys T: see TeSys™ T Motor Management System, page 16-101

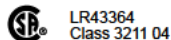
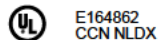

[47] Direct mount to old D2 style D40 to D65 (no Everlink terminations) and to D80 and D95 only.

TeSys™ D Reversing Contactors

Each 3-pole device is prewired with line and load side power wiring for reversing applications. Each 4-pole device is prewired with load side power wiring.

Table 18.27: TeSys D Mechanically-Interlocked Reversing Contactors

	Maximum Horsepower Ratings						Maximum Current (A)		Continuous Current Rating (A)	No. of N.O. Power Poles	Built In Auxiliary Contacts (per contactor)		Catalog Number [48]
	Single-Phase		Three-Phase				Inductive AC3	Resistive AC1			N.O.	N.C.	
	115 V	230 V	200 V	230 V	460 V	575 V							
	1/3	1	2	2	5	7.5	9	20	25	3	1	1	LC2D09[49]
	—	—	—	—	—	—	—	—	—	4	1	1	LC2DT20
	1/2	2	3	3	7.5	10	12	25	25	3	1	1	LC2D12[49]
	—	—	—	—	—	—	—	—	—	4	1	1	LC2DT25
	1	3	5	5	10	15	18	32	32	3	1	1	LC2D18[49]
	—	—	—	—	—	—	—	—	—	4	1	1	LC2DT32
	2	3	7.5	7.5	15	20	25	40	40	3	1	1	LC2D25[49]
	—	—	—	—	—	—	—	—	—	4	1	1	LC2DT40
	2	5	10	10	20	25	32	50	50	3	1	1	LC2D32[49]
	2	5	10	10	20	25	38	50	50	3	1	1	LC2D38[49]
	3	5	10	10	30	30	40	60	60	3	1	1	LC2D40A
	—	—	—	—	—	—	—	—	—	4	—	—	[50]
	3	7.5	15	15	40	40	50	80	70	3	1	1	LC2D50A
	5	10	20	20	40	50	65	80	80	3	1	1	LC2D65A
	—	—	—	—	—	—	—	—	—	4	—	—	[50]
	7.5	15	25	30	60	60	80	125	110	3	1	1	LC2D80
	—	—	—	—	—	—	—	—	—	4	—	—	[50]
	7.5	15	25	30	60	60	95	125	110	3	1	1	LC2D95
	—	—	30	40	75	100	115	—	—	3	1	1	LC2D115[51]
	—	—	—	—	—	—	—	200	160	4	—	—	—
—	—	—	—	—	—	—	—	—	4	—	—	—	LC2D115004 [51]
—	—	40	50	100	125	150	—	—	3	1	1	LC2D150[51]	

TeSys D contactor accessories: TeSys™ D & F Auxiliary Contacts, Time Delay, Mechanical Latch, page 18-15
 TeSys D replacement coils: TeSys™ D AC Coils, page 18-43
 TeSys D dimensions: TeSys™ D Contactors, AC and DC Coil, page 18-51 to TeSys™ D Thermal Overload Relay Dimensions, page 18-59

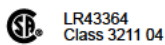
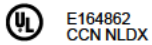

TeSys™ D Capacitor Contactors

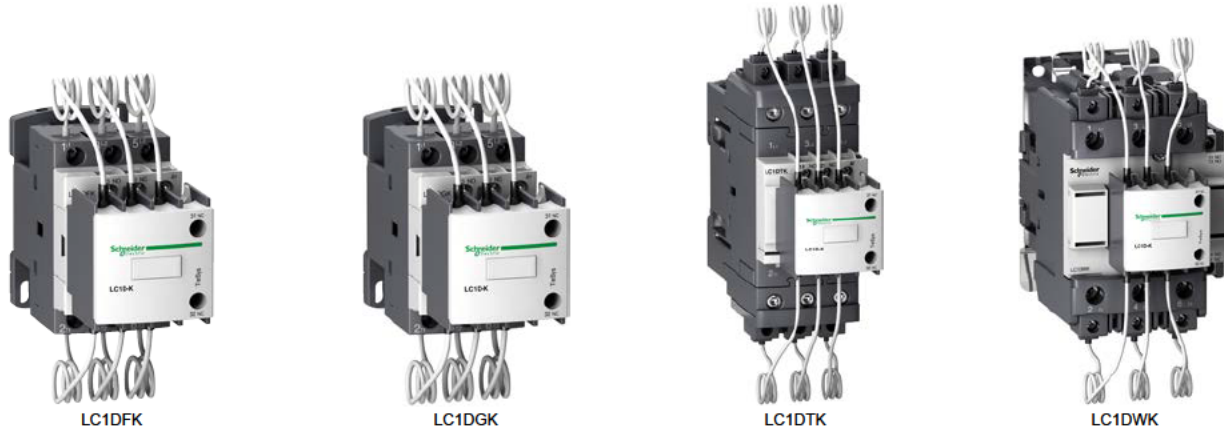

Table 18.28: TeSys D Capacitor Contactors

Maximum Operational Power, kVAR			Instantaneous Auxiliary Contacts		Catalog Number [52]
Three-Phase			N.O.	N.C.	
230 V	460 V	575 V			
6	12.5	15	1	2	LC1DFK
8	16.7	20	1	2	LC1DGK
10	20	25	1	2	LC1DLK
12.5	25	30	1	2	LC1DMK
16.5	33.3	40	1	2	LC1DPK
20	40	50	1	2	LC1DTK
30	60	80	1	2	LC1DWK12

Table 18.29: Coil Voltage Codes for TeSys D Capacitor Contactor (50/60 Hz)

Voltage	24	48	110	120	220	230	240	380	400	415	440
Coil Code	B7	E7	F7	G7	M7	P7	U7	Q7	V7	N7	R7

[48] Includes mechanical interlock without electrical contacts. Installer to complete wiring for electronically interlocking contactor operating coils by using a N.C. auxiliary contact integrated in the contactor or optional LADN or LAD8N auxiliary contact block.

[49] For LC2D09–LC2D38, electrical interlock can be included by adding a V to the end of the catalog number (for example LC2D09B7V).

[50] For these items, order two non-reversing contactors and one mechanical interlock separately. See TeSys™ D Non-Reversing Contactors, page 18-8 for selection.

[51] Includes mechanical interlock (LA9D11502) with prewired electrical contacts for interlocking contactor operating coils.

[52] Complete the catalog number with the voltage code from Table 18.29 Coil Voltage Codes for TeSys D Capacitor Contactor (50/60 Hz), page 18-10 (for example, LC1DFK7).

TeSys™ F Catalog Number Interpretation

Table 18.30: TeSys F Contactors—Interpretation of the Catalog Number^[53]

LC	F		
Full Voltage, Non-Reversing	1		
Full Voltage, Reversing	2		
TeSys F 2, 3, and 4 Pole Contactors 115–800 A			
Contactor AC-3 Full Load Amperes (FLA)			
115 A FLA		115	
150 A FLA		150	
185 A FLA		185	
225 A FLA		225	
265 A FLA		265	
330 A FLA		330	
400 A FLA		400	
500 A FLA		500	
630 A FLA		630	
780 A FLA		780	
800 A FLA		800	
Number of Poles			
2 Poles (400 A, 500 A, and 630 A only)			2
3 Poles (all sizes)			Blank
4 Poles (all sizes except 800 A)			4
Termination Options—Purchase Lugs Separately			
			Blank
Coil Voltage (choose one, noting the contactor size it can be used on)			

AC Coil Voltage	Coil Code	For use on	AC Coil Voltage	Coil Code	For use on
24 V (50 Hz)	B5	LC1F115–F225	230 V (50 Hz)	P5	LC1F115–F225
24 V (60 Hz)	B6	LC1F115–F225	230 V (40–400 Hz)	P7	LC1F115–F800, F1700–F2100
24 V (40–400 Hz)	B7	LC1F225–F400	240 V (50 Hz)	U5	LC1F115–F225
42 V (50 Hz)	D5	LC1F115–F225	240 V (60 Hz)	U6	LC1F115–F225
48 V (50 Hz)	E5	LC1F115–F225	240 V (40–400 Hz)	U7	LC1F115–F780, F1700–F2100
48 V (60 Hz)	E6	LC1F115–F225	277 V (50 Hz)	W5	LC1F115–F225
48 V (40–400 Hz)	E7	LC1F115–F630	277 V (40–400 Hz)	W7	LC1F115–F780, F1700–F2100
110 V (50 Hz)	F5	LC1F115–F225	380 V (50 Hz)	Q5	LC1F115–F225
110 V (60 Hz)	F6	LC1F115–F225	380 V (60 Hz)	Q6	LC1F115–F225
110 V	F7	LC1F1700, F2100	380 V (40–400 Hz)	Q7	LC1F115–F780, F1700–F2100
110 V (40–400 Hz)	F7	LC1F115–F780	400 V (50 Hz)	V5	LC1F115–F225
115 V (50 Hz)	FE5	LC1F115–F225	400 V (40–400 Hz)	V7	LC1F115–F800, F1700–F2100
115 V (40–400 Hz)	FE7	LC1F115–F780	415 V (50 Hz)	N5	LC1F115–F225
120 V (60 Hz)	G6	LC1F115–F225	415 V (40–400 Hz)	N7	LC1F115–F780, F1700–F2100
120 V (40–400 Hz)	G7	LC1F115–F400	440 V (50 Hz)	R5	LC1F115–F225
120 V (40–400 Hz)	F7	LC1F500–F780, F170–F2100	440 V (40–400 Hz)	R7	LC1F115–F780, F1700–F2100
127 V (60 Hz)	G6	LC1F115–F225	460/480 V (60 Hz)	Q6	LC1F115–F225
127 V (40–400 Hz)	G7	LC1F115–F780	480 V (40–400 Hz)	N7	LC1F780
200/208 V (60 Hz)	L6	LC1F115–F225	500 V (50 Hz)	S5	LC1F115–F225
200/208 V (40–400 Hz)	L7	LC1F265–F780	500 V (40–400 Hz)	S7	LC1F115–F780, F1700–F2100
208 V (40–400 Hz)	L7	LC1F115–F225	600 V (40–400 Hz)	X7	LC1F500–F630
220 V (50 Hz)	M5	LC1F115–F225	660 V (60 Hz)	Y6	LC1F115–F225
220 V (60 Hz)	M6	LC1F115–F225			
220 V (40–400 Hz)	M7	LC1F115–F780, F1700–F2100			

DC Coil Voltage	Coil Code	For use on
24 V	BD	LC1F115–F400
48 V	ED	LC1F115–F630
110 V	FD	LC1F115–F780, LC1F1700–F2100
110 V	FW	LC1F800
125 V	GD	LC1F115–F780, LC1F1700–F2100
220 V	MD	LC1F265–F780
220/240 V	MW	LC1F800
250 V	UD	LC1F115–F780, LC1F1700–F2100
380/400 V	QW	LC1F800
440 V	RD	LC1F115–F780, LC1F1700–F2100

[53] Use this table only to interpret current catalog numbers. Some combinations are not available.

TeSys™ F Non-Reversing Contactors

Table 18.31: TeSys F Contactors—2, 3, and 4 Pole

	Maximum Three-Phase Horsepower Ratings				Maximum Current (A)		Continuous Current Rating (A)	Number of Poles	Catalog Number [54]	
	200 V	230 V	460 V	575 V	Inductive AC-3	Resistive AC-1				
	30	40	75	100	115	200	175	3	LC1F115	
	40	50	100	125	150	250	200	4	LC1F1154	
	50	60	125	150	185	275	200	3	LC1F150	
	60	75	150	150	225	315	250	4	LC1F1504	
	60	75	150	200	265	350	285	3	LC1F185	
	75	100	200	250	330	400	370	4	LC1F1854	
	100	125	250	300	400	500	420	3	LC1F225	
	150	200	400	500	500	700	700	4	LC1F2254	
	250	300	600	800	630	1000	1000	3	LC1F265	
	350	400	800	900	800	1000	1000	4	LC1F2654	
	—	450	900	900	780	1600	1350	3	LC1F330	
	Current Rated						1400	1400	4	LC1F3304
							1700	1700	2	LC1F4002
							2100	2100	3	LC1F4003
									4	LC1F4004
									2	LC1F5002
									3	LC1F5003
									4	LC1F5004
									2	LC1F6302
									3	LC1F6303
								4	LC1F6304	
								3	LC1F800	
								4	LC1F8004	
								3	LC1F780	
								4	LC1F7804	
								3	LC1F1400	
								4	LC1F1700	
								3	LC1F2100	

Table 18.32: TeSys F Coil Voltage Codes [55]

Contactor	Hz	Coil Prefix	24 V	48 V	110 V	120 V	208 V	220 V	240 V	440 V	480 V
AC											
F115, F150, F185, and F225	50	LX1	B5	E5	F5	—	—	M5	U5	—	—
	60	LX1	B6	E6	F6	G6	L6	M6	U6	R6	Q5
	40-400	LX9	—	E7	F7	G7	L7	M7	U7	R7	S7
F265 and F330	40-400	LX1	B7	E7	F7	G7	L7	M7	U7	R7	S7
F400-F780	40-400	LX1	—	E7	F7	G7	L7	M7	U7	R7	S7
F1400-F2100	40-400	LX1	—	—	F7	G7	L7	M7	U7	R7	S7
DC [56]											
F115-F330		LX4	BD	ED	FD	GD	MD	UD	RD		
F400-F630		LX4	—	ED	FD	GD	MD	UD	RD		
F780, F1400-F2100		LX4	—	—	FD	GD	MD	UD	RD		

Table 18.33: Coil Voltage Codes for AC and DC Voltages for F800 (includes built-in surge suppressor)

Vac/Vdc	Hz	Coil Prefix	110 V	120 V	127 V	220 V	240 V	380 V	400 V	415 V
Code	40-400	LX4	FW	FW	FW	MW	MW	QW	QW	QW

TeSys™ F Overload Relays

Table 18.34: TeSys F 3-Phase Overload Relays—Solid State, Separate Mounting [57]

Current Setting Range A	For Direct Mounting to Contactor LC1••••	Class 10 Catalog Number	Class 20 Catalog Number	Class 10/20 Selectable Catalog Number
30-50	F115-F185	LR9F5357	LR9F5557	LR9F57
48-80	F115-F185	LR9F5363	LR9F5563	LR9F63
60-100	F115-F185	LR9F5367	LR9F5567	LR9F67
90-150	F115-F185	LR9F5369	LR9F5569	LR9F69
132-220	F185[58]-F400	LR9F5371	LR9F5571	LR9F71
200-330	F225-F500	LR9F7375	LR9F7575	LR9F75
300-500	F330-F500	LR9F7379	LR9F7579	LR9F79
380-630	F400-F630, F800	LR9F7381	LR9F7581	LR9F81

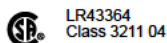
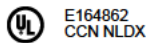

TeSys F contactor accessories: TeSys™ D and F Accessories, page 18-16
 TeSys F overload relay accessories: TeSys F Overload Relay Accessories, page 18-22
 TeSys F replacement coils and parts: TeSys F Contact Kits, Arc Chambers, page 18-48, TeSys F AC Coils, page 18-44, and TeSys F DC Coils, page 18-47
 TeSys F dimensions: TeSys F Contactors, Dimensions, page 18-53, TeSys™ F Overload Relay Dimensions, page 18-61

[54] Complete the catalog number with the coil voltage code from Table 18.32 TeSys F Coil Voltage Codes, page 18-12 and Table 18.33 Coil Voltage Codes for AC and DC Voltages for F800, page 18-12 (for example, LC1F115G7). All coils except F780 include 1 N.O. holding circuit interlock contact. The F780 uses 2 coils that must be wired in series.

[55] For additional voltage codes refer to the Control and Protection Components Catalog MKTED210011EN.

[56] DC coils for 3-pole contactors are fitted with built-in surge suppression as standard.

[57] When mounting overload relays LR9F5•57-LR9F5•71 and LR9F57-LR9F71 directly beneath the contactor, supporting the relays with a mounting plate is recommended. With overload relays LR9F7•75-LR9F7•81 and LR9F75-LR9F81, use of a support mounting plate is mandatory. Refer to TeSys F Overload Relay Accessories, page 18-22.

[58] Interconnection kit LA7F407 is required to mount an LR9F5•71 and LR9F71 to an LC1F185.

TeSys™ F Reversing Contactors

Components are available for customer assembly of TeSys F reversing contactors. For example, the following components must be ordered to build a reversing contactor, 75 hp @ 460 V, with a 120 V / 60 Hz coil:



LC1F265

Table 18.35: Example of Components

Description	Quantity	Catalog Number
Contactors	2	LC1F115G6
Lugs (Suppressor Blocks, Lugs, page 18-21)	6	DZ2FF1
Auxiliary contacts	2	LADN11
Power connections	1	LA9FF976
Mechanical interlock	1	LA9FF970

Table 18.36: 3-Pole Contactors

Maximum Three-Phase Horsepower Ratings				Maximum Current (A)		Continuous Current Rating (A)	Holding Circuit Contact Built Into Coil		Catalog Number ^[59]
200 V	230 V	460 V	575 V	Inductive AC3	Resistive AC1		N.O.	N.C.	
30	40	75	100	115	200	175	1	0	LC1F115
40	50	100	125	150	250	200	1	0	LC1F150
50	60	125	150	185	275	200	1	0	LC1F185
60	75	150	150	225	315	250	1	0	LC1F225
60	75	150	200	265	350	285	1	0	LC1F265
75	100	200	250	330	400	370	1	0	LC1F330
100	125	250	300	400	500	420	1	0	LC1F400
150	200	400	500	500	700	700	1	0	LC1F500
250	300	600	800	630	1000	1000	1	0	LC1F630
350	400	800	900	800	1000	1000	0	0	LC1F800
—	450	900	900	780	1600	1350	0	0	LC1F780

Table 18.37: Auxiliary Contact (Electrical Interlocking)—2 must be purchased

For use with	Number of Contacts	Maximum Number of Blocks Per Contactor	Contact Arrangement		Catalog Number
			N.O.	N.C.	
LC1F to be ordered separately	1	1	1	—	LADN10 ^[60]
			—	1	LADN01
	2	2	1	1	LADN11
			2	—	LADN20 ^[60]
	4	2	2	2	LADN22
			1	3	LADN13
			4	—	LADN40 ^[60]
			—	4	LADN04
			3	1	LADN31
			2	2	LADC22 ^[61]

Table 18.38: Accessories—For the Assembly of 3-Pole Reversing Contactors (Horizontal Mounting)

With 2 Identical Contactors ^[62]	Set of Power Connections Catalog Number	Horizontal Mounting Mechanical Interlock Kit Catalog Number
LC1F115	LA9FF976	LA9FF970
LC1F150	LA9F15076	LA9FF970
LC1F185	LA9FG976	LA9FG970
LC1F225	LA9F22576	LA9FG970
LC1F265	LA9FH976	LA9FJ970
LC1F330	LA9FJ976	LA9FJ970
LC1F400	LA9FJ976	LA9FJ970
LC1F500	LA9FK976	LA9FJ970
LC1F630, F800	LA9FL976	LA9FL970

Table 18.39: Definite Purpose Ratings, 3-Phase, Breaking All Lines, 100,000 Cycles (Hermetic Refrigeration Compressor)

Device	FLA	LRA		
		240 V	480 V	600 V
LC1D09 (AC coil only)	9	54	45	36
LC1D12 (AC coil only)	12	72	60	48
LC1D18 (AC coil only)	18	108	90	72
LC1D25 (AC coil only)	25	150	125	100
LC1D32 (AC coil only)	32	192	160	128
LC1D40A	40	240	200	160
LC1D50A	50	300	250	200
LC1D65A	65	390	325	260
LC1D80	75	450	375	300
LC1D115	115	690	575	460
LC1D150	150	900	750	600

TeSys F contactor accessories: TeSys™ D and F Accessories, page 18-16
 TeSys F overload relay accessories: TeSys F Overload Relay Accessories, page 18-22
 TeSys F replacement coils and parts: TeSys F Contact Kits, Arc Chambers, page 18-48, TeSys F AC Coils, page 18-44, and TeSys F DC Coils, page 18-47
 TeSys F dimensions: TeSys™ F Contactors, Dimensions, page 18-53



E164862
CCN NLDX



LR43364
Class 3211 04



^[59] Complete the catalog number with the coil voltage code from TeSys F Coil Voltage Codes, page 18-12 and Coil Voltage Codes for AC and DC Voltages for F800, page 18-12 (for example, LC1F115G7). All coils except F780 include 1 N.O. holding circuit interlock contact. The F780 uses 2 coils that must be wired in series.

^[60] Cannot be used for interlocking.

^[61] Including 1 N.O. + 1 N.C. make-before-break overlapping contacts.

^[62] For two contactors of different size, refer to pages Component parts, Vertical Mounting, page 18-20



TeSys™ K Contactors

Table 18.40: Instantaneous Auxiliary Contact Blocks

Clip-on front mounting, 1 block per contactor and 2 blocks per pair of mechanically interlocked contactors				
Type of connection	Auxiliary Contacts		Catalog Number	
	N.O.	N.C.		
Screw clamp	2	—	LA1KN20	
	—	2	LA1KN02	
	1	1	LA1KN11	
	4	—	LA1KN40 ^[1]	
	3	1	LA1KN31 ^[1]	
	2	2	LA1KN22 ^[1]	
	1	3	LA1KN13 ^[1]	
	—	4	LA1KN04 ^[1]	
	Slip-on 1 x 0.250 in. or 2 x 0.110 in.	2	—	LA1KN207
		—	2	LA1KN027
1		1	LA1KN117	
4		—	LA1KN407 ^[1]	
3		1	LA1KN317 ^[1]	
2		2	LA1KN227 ^[1]	
1		3	LA1KN137 ^[1]	
—		4	LA1KN047 ^[1]	

Table 18.41: Electronic Time Delay Auxiliary Contact Blocks

Clip-on front mounting, 1 block per contactor and 2 blocks per pair of mechanically interlocked contactors				
Voltage (V)	Type	Timing Range (S)	Contacts	Catalog Number
24–48 Vac or Vdc	On-delay	1–30	SPDT	LA2KT2E
110–240 Vac	On-delay	1–30	SPDT	LA2KT2U

NOTE: Relay outputs, with single pole double throw, 240 Vac/Vdc, 2 A max.
Maximum switching capacity 250 VA / 150 W
Operating temperature: –10 to +60°C (14 to 140°F)
Reset time: 1.5 s during time delay, 0.5 after time delay

Table 18.42: Suppressor Module with Incorporated LED Indicator



Clip-on front mounting			
Voltage range	Type	Sold in lots of	Catalog Number
12–24 Vac/Vdc	Varistor	5	LA4KE1B ^[2]
32–48 Vac/Vdc	Varistor	5	LA4KE1E ^[2]
50–129 Vac/Vdc	Varistor	5	LA4KE1FC ^[2]
130–250 Vac/Vdc	Varistor	5	LA4KE1UG ^[2]
12–24 Vdc	Diode + Zener	5	LA4KC1B ^[3]
32–48 Vdc	Diode + Zener	5	LA4KC1E ^[3]
220–250 Vac	RC	5	LA4KA1U ^[4]

Table 18.43: Paralleling Links

Description	Sold in lots of	Catalog Number
For 2 poles with screw-clamp terminals	4	LA9E01
For 4 poles with screw-clamp terminals	2	LA9E02

Table 18.44: Power Connectors

Description	Sold in lots of	Catalog Number
Set of 6 power connections for reversing contactors with screw-clamp terminals	100	LA9K0969
Set of 4 power connections for changeover contactors with screw-clamp terminals	100	LA9K0970

Table 18.45: Marking Strips

Description	Sold in lots of	Catalog Number
Clips onto front of the contactor	100	LA9D90

Table 18.46: Accessories for Overload Relays

Description	Type of Connection	Catalog Number
Terminal block for separate clip-on mounting of the overload relay onto 35 mm omega rail (AM1DP200)	Screw-clamp	LA7K0064



[1] Block of 4 contacts cannot be used with LP4K or LP5K contactors.
 [2] Protection by limitation of the transient voltage to 2 Uc maximum. Maximum reduction of the transient voltage peaks. Slight time delay on drop-out (1.1–1.5 times normal).
 [3] No overvoltage or oscillation frequency. Polarized component. Slight time delay on drop-out (1.1–1.5 times normal).
 [4] Protection by limitation of the transient voltage to 3 Uc maximum and limitation of the oscillation frequency. Slight time delay on drop-out (1.2 times normal).

TeSys™ D and F Auxiliary Contacts, Time Delay, Mechanical Latch
Table 18.47: Standard, Instantaneous Auxiliary Contact Blocks

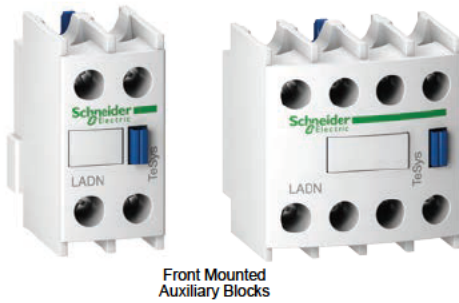

Snap-On Mounting	Number of Contacts	Contact Arrangement		Catalog Number [5]
		N.O.	N.C.	
To front of LC•DT20–D258 (4P), LC•D09–D150 [5] or To right side of LC•F	4 [5]	2	2	LADN22 [6]
		1	3	LADN13 [6]
		4	0	LADN40 [6]
		0	4	LADN04 [6]
		3	1	LADN31 [6]
		2	2	LADC22 [6] [7]
To front of LC•D80–D150 or To left side of LC•F	2	1	1	LADN11 [6]
		2	0	LADN20 [6]
		0	2	LADN02 [6]
To side of LC•D09 to D150 only (not for use on TeSys F)	1	1	0	LADN10 [8]
		0	1	LADN01 [8]
	2	1	1	LAD8N11 [9]
		2	0	LAD8N20 [9]

Table 18.48: Instantaneous Blocks with Dust-Tight Auxiliary Contacts (IP54) NEMA 12

Snap-On Mounting	Standard Contacts		Dust-Tight Contacts		Catalog Number
	N.O.	N.C.	N.O.	N.C.	
To front of LP•D40–D80, LC•DT20–D258 (4P), LC•D09 to D95 or To right side of LC•F	—	—	2	—	LA1DX20
	2	—	2	—	LA1DZ40
	1	1	2	—	LA1DZ31
	—	—	2	—	LA1DY20 [10]

Table 18.49: Pneumatic Time Delay Contact Blocks

Snap-On Mounting	Time Delay Contacts		Type	Range of Time Delay	Catalog Number [11]
	N.O.	N.C.			
To front of LP•D40–D80, LC•DT20–D258 (4P), LC•D09 to D150 or To right side of LC•F	1	1	On energization (on delay)	0.1 to 3 s [12]	LADT0
				0.1 to 30 s	LADT2
				10 to 180 s	LADT4
	1	1	On de-energization (off-delay)	1 to 30 s [13]	LADS2
				0.1 to 3 s [12]	LADR0
				0.1 to 30 s	LADR2
			10 to 180 s	LADR4	

Table 18.50: Mechanical Latch Blocks with Manual or Electrical Unlatch (TeSys D only)

Front snap-on mounting onto	Application	Catalog Number [14]
LC•D09 to D65A	For silent operation and energy conservation	LAD6K10 [15] [16]
LC1D80 to D150, LP1D80	For silent operation and energy conservation	LA6DK20 [15]

Table 18.51: Coil Voltage Codes for LA6DK Mechanical Latch Blocks

Volts	12	24	32/36	42/48	60/72	100	110/127	200/208	220/240	380/415	440/480	500/600
AC or DC	J	B	C	E	EN	K	F	L	M	Q	R	S



TeSys D contactors: TeSys™ D Non-Reversing Contactors, page 18-8 and TeSys™ D Reversing Contactors, page 18-10
 TeSys D overload relay accessories: TeSys D Overload Relay Accessories, page 18-22
 TeSys D replacement coils: TeSys™ D AC Coils, page 18-43
 TeSys D dimensions: TeSys™ D Contactors, AC and DC Coil, page 18-51 to TeSys™ D Thermal Overload Relay Dimensions, page 18-59

[5] For low consumption coils (LC1D09–D38 only), only one front-mounted two-contact block allowed. No side-mounted contact blocks allowed.
 [6] For spring terminal versions of these blocks, add a 3 to the end of the catalog number (for example, LADN223). For slip-on versions, add 9 to the end of the catalog number (for example, LADN229).
 [7] Including 1 N.O. + 1 N.C. make-before break overlapping contacts.
 [8] This block cannot be added to the LC1D 09–D38 contactors; a maximum of 2 blocks can be mounted on the LC1D40A-LC1P1D80 contactors only.
 [9] 1 block may be added to the left side of LC1D09–D38, AC coils only; only 1 block may be added to either side of the LC1D40A-D80 contactors, AC coils only. Cannot be installed on TeSys D contactors with DC coils.
 [10] Device supplied with 4 ground terminal points.
 [11] For spring terminal versions of these blocks, add a 3 to the end of the catalog number (for example, LADT23).
 [12] Scale range is expanded between 0.1 and 0.6 seconds on the dial for more accurate settings at the lower end of the range.
 [13] Switching time between the opening of the N.C. contact and the closing of the N.O. contact: 40 ms ± 15 ms.
 [14] To complete the catalog number, add the coil voltage code from Table 18.51 Coil Voltage Codes for LA6DK Mechanical Latch Blocks, page 18-15 (for example, LAD6K10F).
 [15] Does not include internal coil clearing contact.
 [16] Low consumption DC contactors (and relays) (code coil •L) are not compatible with the LAD6K10• mechanical latching blocks.

TeSys™ D and F Accessories

Table 18.52: For Power Pole or Control Connection

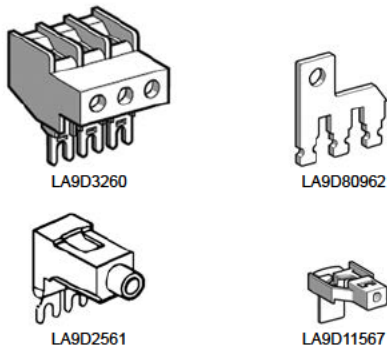

Description		For use with contactors LC1/LP1	Sold in lots of	Catalog Number		
Connectors for larger cable sizes	4 poles	#8 AWG (10 mm ²)	DT20, DT25	1	LAD92560	
	3 poles	#4 AWG (25 mm ²)	D09–D38	1	LA9D3260	
Everlink™ terminal block	3 poles		D40A–D65A	1	LAD96560	
Links for the parallel connection of:	2 poles		D09–D38	10	LA9D2561	
			D40A–D65A	1	LAD9P32	
			D80, D95	2	LA9D80961	
			F115	4	LA9FF602	
			F150, F185	4	LA9FG602	
			F225, F265, F330, F400	4	LA9FH602	
			F500	4	LA9FK602	
	3 poles (wye-delta shorting strap)			F630, F800	4	LA9FL602
				D09–D38	10	LAD9P3
				D40A–D65A	1	LAD9P33
				D80, D95	1	LA9D80962
				F115	1	LA9FF601
				F150, F185	1	LA9FG601
				F225, F265, F330, F400	1	LA9FH601
4 poles			F500	1	LA9FK601	
			F630, F800	1	LA9FL601	
Second coil connection			DT20, DT25	2	LA9D1263	
Control circuit take-off from main pole			D80, D95	2	LA9D80963	
Spreaders for increasing pole pitch to 45 mm			D115, D150	10	LA9D09966	
Replacement power terminal block			D80, D95	10	LA9D8067	
			D115, D150	10	LA9D11567	
Spreaders for increasing pole pitch to 45 mm			D115, D150	3	GV7AC03	
Replacement power terminal block			D115, D150	1	LA9D115603	

Table 18.53: For Marking

Description	For use with contactors LC1/LP1	Sold in lots of	Catalog Number
Reference label holder snap-on 8 x 22 mm	4-pole contactors D80–D115	100	LA9D92
Reference label holder snap-on 8 x 18 mm 3 poles	D09–D65A, DT20–DT80A, LADN, LADT, LADR	100	LAD90
Sheet of 300 labels self adhesive 7 x 21 mm	For holder LA9D92	1	LA9D93

Table 18.54: For Mounting

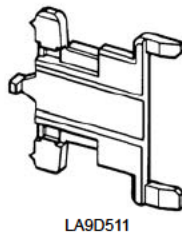

Description	For use with contactors LC1/LP1	Sold in lots of	Catalog Number
Set of shims for mounting LAD8N and LA8DN	D80 to D95	1	LA9D511
Retrofit plate for replacement of LC1D40-D65 with LC1D40A-D65A	D40A–D65A	1	LAD7X3
35 mm DIN Rail – 2 meters long	LC1D09 to D80	10	AM1DP200

Table 18.55: Replacement Contacts

	For use with contactors		Catalog Number
Three-pole	LC1D115	3 poles	LA5D1158031
	LC1D150	3 poles	LA5D150803
Four-pole	LC1D115	4 poles	LA5D115804

Table 18.56: Arc Chambers

	For use with contactors		Catalog Number
Three-pole	LC1D115	3 poles	LA5D11550
	LC1D150	3 poles	LA5D15050
Four-pole	LC1D115	4 poles	LA5D115450

TeSys D contactors: TeSys™ D Non-Reversing Contactors, page 18-8 and TeSys™ D Reversing Contactors, page 18-10
 TeSys D overload relay accessories: TeSys D Overload Relay Accessories, page 18-22
 TeSys D contactor accessories: TeSys™ D & F Auxiliary Contacts, Time Delay, Mechanical Latch, page 18-15
 TeSys D replacement coils: TeSys™ D AC Coils, page 18-43
 TeSys D dimensions: TeSys™ D Contactors, AC and DC Coil, page 18-51 to TeSys™ D Thermal Overload Relay Dimensions, page 18-59
 TeSys F contactors: TeSys™ F Non-Reversing Contactors, page 18-12 and TeSys™ F Reversing Contactors, page 18-13
 TeSys F replacement coils and parts: TeSys F Contact Kits, Arc Chambers, page 18-48, TeSys F AC Coils, page 18-44, and TeSys F DC Coils, page 18-47

RC and Varistor Coil Suppressors

RC Coil Suppressor



LA4DA1U

- Limitation of transient voltage to 300% of nominal voltage maximum.
- Oscillating frequency limited to 400 Hz maximum. Slight increase in drop-out time (1.2 to 2 times normal).

Table 18.57: Resistor/Capacitor Circuit (RC) for Reduction of Electrical Noise in AC Contactor Coils

Installed by	Mounting on	Operating Voltage 50/60 Hz	Catalog Number
Snapping into the cavity on the right side without tools ^[17]	LC•D09 to D38 (3P), LC1DT20 to DT40 (4P)	24–28 Vac	LAD4RCG
		50–127 Vac	LAD4RCG
		110–240 Vac	LAD4RCU
Snap-on mounting, and connection without tools to the contactor coil terminals	LC1D40A to 65A (3P), LC1DT60A to DT80A (4P)	24–48 Vac	LAD4RC3E
		50–127 Vac	LAD4RC3G
		110–240 Vac	LAD4RC3U
		380–415 Vac	LAD4RC3N
Screw connection to the contactor coil terminals	LC•D80 to D150 (3P), LC1D80 to D115 (4P)	24–48 Vac	LA4DA2E
		50–127 Vac	LA4DA2G
		110–240 Vac	LA4DA2U
		380–415 Vac	LA4DA2N

Varistor Coil Suppressor

- Limitation of transient voltage value to 200% of nominal voltage maximum.
- Maximum reduction of transient voltage peaks. Slight increase in drop-out time (1.1 to 1.5 times normal).

Table 18.58: Varistor (Peak Limiting) for Reduction of Electrical Noise in AC Contactor Coils

Installed by	Mounting on	Operating Voltage	Catalog Number
Snapping into the cavity on the right side without tools ^[17]	LC•D09 to D38 (3P), LC1DT20 to DT40 (4P)	24–48 Vac	LAD4VE
		50–127 Vac	LAD4VG
		110–250 Vac	LAD4VU
Snap-on mounting, and connection without tools to the contactor coil terminals	LC1D40A to D65A (3P), LC1DT60A to DT80A (4P)	24–48 Vac/Vdc	LAD4V3E
		50–127 Vac/Vdc	LAD4V3G
		110–250 Vac/Vdc	LAD4V3U
Screw connection to the contactor coil terminals	LC•D80 to D115 (3P), LC1D80 to D115 (4P)	24–48 Vac	LA4DE2E
		50–127 Vac	LA4DE2G
		110–250 Vac	LA4DE2U
Screw connection to the contactor coil terminals	LC•D80 to D95 (3P), LC1D80 (4P)	24–48 Vdc	LA4DE3E
		50–127 Vdc	LA4DE3G
		110–250 Vdc	LA4DE3U

Diode Coil Suppressor

- No overvoltage or oscillating frequency.
- Polarized component. Increased drop-out time (6–10 times normal).

Table 18.59: Diode for Reduction of Electrical Noise in DC Contactor Coils

Installed on the upper part by	Mounting on	Operating Voltage, DC	Catalog Number
Snap-on mounting and connection w/o tools to the contactor coil terminals	LC•D09 to D38 (3P), LC1DT20 to DT40 (4P)	24–250 Vdc	LAD4DDL
Clip-on front mounting	LC•D40A to D65A (3P), LC1DT60A to DT80A (4P)	24–250 Vdc	LAD4D3U
Screw connection of wire to the contactor coil terminals	LC•D80 to D95 (3P), LC1D80 (4P)	24–250 Vdc	LA4DC3U



LA4DC3U

[17] Installing the suppressor into the cavity makes the electrical connection. Overall width of the contactor remains the same.

Bidirectional Diode Coil Suppressor

- Protection provided by limiting the transient voltage to 2 Uc max.
- Maximum reduction of transient voltage peaks

Table 18.60: Bidirectional Peak Limiting Diode



Installed by	Mounting on	Operating Voltage		Catalog Number
		Vac (50/60 Hz)	Vdc	
Snapping into the cavity on the right side of the contactor [18]	LC•D09 to D38 (3P) [19] LC1DT20 to DT40 (4P)	24	—	LAD4TB
		—	24	LAD4TBDL
		72	—	LAD4TS
		—	72	LAD4TSDL
		—	125	LAD4TGDL
		—	250	LAD4TUDL
Clip-on front mounting and connection without tools to the contactor coil terminals [19]	LC•D40A to D65A (3P), LC1DT60A to DT80A (4P)	—	600	LAD4TXDL
		12–24	12–24	LAD4T3B
		25–72	25–72	LAD4T3S
		73–125	73–125	LAD4T3G
		126–250	126–250	LAD4T3U
		251–440	251–440	LAD4T3R
Screw mounting [20]	LC•D80 to D95 (3P), LC1D80 (4P)	12–24	12–24	LA4DB2B
		25–72	25–72	LA4DB2S
		—	24	LA4DB3B
		—	72	LA4DB3S

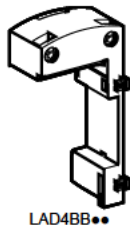

Table 18.61: Cabling Accessories

Usage	Mounting on	Operating Voltage 50/60 Hz	Catalog Number	
For adapting existing wiring to a new product or for use with top-mounting accessory.	LC1D09 to D38	Without coil suppression	LAD4BB	
		With coil suppression (varistor)	24-48 Vac 50-127 Vac 110-250 Vac	LAD4BBVE LAD4BBVG LAD4BBVU
		Without coil suppression	LAD4BB3	
For adapting existing wiring to a new product or for use with top-mounting accessory	LC1D40A to D65A	Without coil suppression	LAD4BB3	

TeSys D contactors: TeSys™ D Non-Reversing Contactors, page 18-8 and TeSys™ D Reversing Contactors, page 18-10
 TeSys D contactor accessories: TeSys™ D F Auxiliary Contacts, Time Delay, Mechanical Latch, page 18-15
 TeSys D overload relay accessories: TeSys D Overload Relay Accessories, page 18-22
 TeSys D replacement coils: TeSys™ D AC Coils, page 18-43
 TeSys D dimensions: TeSys™ D Contactors, AC and DC Coil, page 18-51 to TeSys™ D Thermal Overload Relay Dimensions, page 18-59

TeSys™ D Electronic Timers and Interface Modules

The following accessories require use of cabling accessories (LAD4BB••) for proper mounting. See Bidirectional Diode Coil Suppressor, page 18-18 for illustration.

Table 18.62: Electronic Serial Timer Modules

Type	Operational Voltage [21]		Time Delay	Catalog Number
	24–250 Vac	100–250 Vac		
On-delay	LC1D09–D65A	LC1D80–D150	0.1–2 s	LA4DT0U
			1.5–30 s	LA4DT2U
			25–500 s	LA4DT4U

Table 18.63: Interface Modules



Interface Type [22]	Operational Voltage		Input Voltage	Catalog Number
	24–250 Vac	100–250 Vac		
Relay	LC1D09–D150	—	24 Vdc	LA4DFB
	LC1D09–D150	—	48 Vdc	LA4DFE
Relay Plus Manual Operation	LC1D09–D150	—	24 Vdc	LA4DLB
	LC1D09–D150	—	48 Vdc	LA4DLE
Solid State	LC1D09–D65A	LC1D80–D115	24 Vdc	LA4DWB

Table 18.64: Automatic-Manual-Stop Control Modules

Operational Voltage		Catalog Number
24–100 Vac	100–250 Vac	
LC1D09–D150	—	LA4DMK

Table 18.65: TeSys Safety-Chain Identification System ^{New!}



Description	Compatibility	Package Qty	Catalog Number
Red retrofit contactor safety cover	LC1D09 to D65A, CAD32, CAD50	10	LAD9ET1S
	LC1D80	1	LAD9ET3S
	LC1D115 to D150	1	LAD9ET4S
Red auxiliary contact block, 2 N.O. + 2 N.C.	LC1D09 to D150, CAD32, CAD50	1	LADN22S
Red retrofit safety sticker	TeSys U	10	LU9ET1S

[18] Installing the suppressor into the cavity makes the electrical connection. Overall width of the contactor remains the same.

[19] For LC•D09–LC•D65A with DC or low consumption DC coils, 3-pole contactors are fitted with built-in bidirectional diode suppression as standard.

[20] Mounting at the top of the contactor on coil terminals A1 and A2.

[21] For 24 V operation, the contactor must be fitted with a 21 V coil: coil voltage code Z5 for 50 Hz; Z6 for 60 Hz; and ZD for DC.

[22] Adapter required for D09–D65A, see Cabling Accessories, page 18-18.

TeSys™ D Reversing Contactors

Table 18.66: Contactors

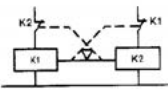
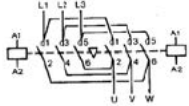
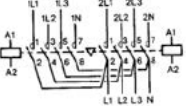
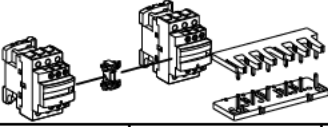
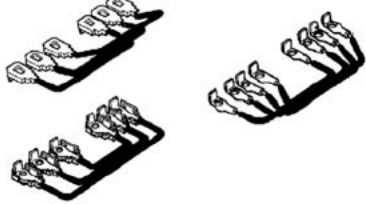
Reversing contactors comprising two identical, horizontally mounted contactors:	Mechanical interlock		Set of power connections	
	Without electrical interlock	With incorporated electrical interlock (2 N.C. contacts)	Reversing contactors for motor control	Four pole contactors
LC1D09, LC1D12, LC1D18, LC1D25, LC1D32, LC1D38 LC1DT20, LC1DT25, LC1DT32, LC1DT40				
	Catalog Number LAD9R1 [23]	Catalog Number LAD9R1V [23]	Catalog Number Included with kit	Catalog Number —
	LADT9R1 [23]	LADT9R1V [23]	—	Included with kit
LC1D40A, D50A, D65A			LAD4CM LAD9R3 [24]	LA9D65A69
LC1D80 and D95 (AC coil) LC1D80 and D95 (DC coil)	LA9D50978 LA9D80978	LA9D4002 LA9D8002	LA9D8069 LA9D8069	LA9D8070 LA9D8070
LC1D115 and LC1D150	Not Available	LA9D11502	LA9D11569	LA9D11570 (4P) (D115 only)
				

TeSys D contactors: TeSys™ D Non-Reversing Contactors, page 18-8 and TeSys™ D Reversing Contactors, page 18-10
 TeSys D contactor accessories: TeSys™ D & F Auxiliary Contacts, Time Delay, Mechanical Latch, page 18-15
 TeSys D replacement coils: TeSys™ D AC Coils, page 18-43
 TeSys D dimensions: TeSys™ D Contactors, AC and DC Coil, page 18-51 to TeSys™ D Thermal Overload Relay Dimensions, page 18-59

[23] Kit including mechanical interlock and wiring.
 [24] Kit combines both LAD4CM and LA9D65A69

TeSys™ F Component Parts and Vertical Mounting

Table 18.67: Component Parts for the Assembly of F-Line 3-pole Reversing Contactors

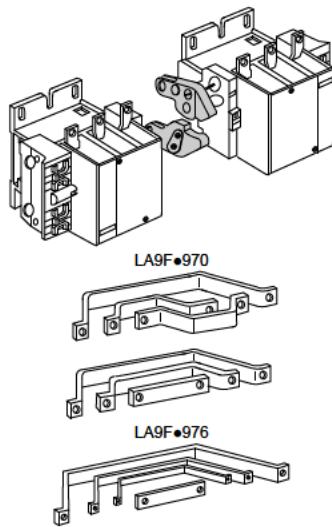

With 2 Identical Contactors	Set of Power Connections Cat. No.	Mechanical Interlock Kit Cat. No.
Horizontal Mounting		
LC1F115	LA9FF976	LA9FF970
LC1F150	LA9F15076	LA9FF970
LC1F185	LA9FG976	LA9FG970
LC1F225	LA9F22576	LA9FG970
LC1F265	LA9FH976	LA9FJ970
LC1F330	LA9FJ976	LA9FJ970
LC1F400	LA9FJ976	LA9FJ970
LC1F500	LA9FK976	LA9FJ970
LC1F630 or F800	LA9FL976	LA9FL970
Vertical Mounting		
LC1F115 or F150	[25]	LA9FF4F
LC1F185 or F225	[25]	LA9FG4G
LC1F265	[25]	LA9FH4H
LC1F330	[25]	LA9FJ4J
LC1F400	[25]	LA9FJ4J
LC1F500	[25]	LA9FK4K
LC1F630 or F800	[25]	LA9FL4L
LC1F780	[26]	LA9FX970 [26]

Table 18.68: Component Parts for the Assembly of TeSys F 3-pole or 4-pole Transfer Contactors

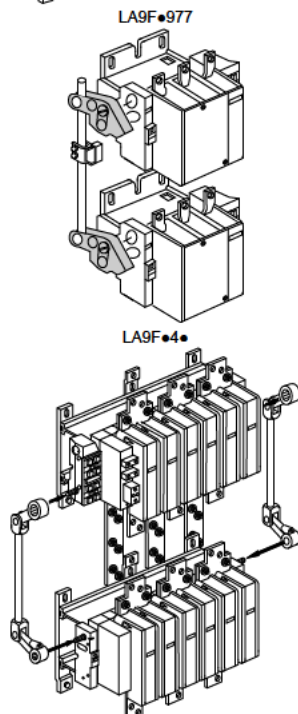

Mounting	Set of Power Connections		Mechanical Interlock Kit Cat. No.
	Three-Pole	Four-Pole	
Horizontal Mounting			
LC1F115/4	LA9FF982	LA9FF977	LA9FF970
LC1F150/4	LA9F15082	LA9F15077	LA9FF970
LC1F185/4	LA9FG982	LA9FG977	LA9FG970
LC1F225/4	LA9F22582	LA9F22577	LA9FG970
LC1F265/4	LA9FH982	LA9FH977	LA9FJ970
LC1F330/4	LA9FJ982	LA9FJ977	LA9FJ970
LC1F400/4	LA9FJ982	LA9FJ977	LA9FJ970
LC1F500/4	LA9FK982	LA9FK977	LA9FJ970
LC1F630/4	LA9FL982	LA9FL977	LA9FL970
Vertical Mounting			
LC1F115/4 or F150/4	[25]	[25]	LA9FF4F
LC1F185/4 or F225/4	[25]	[25]	LA9FG4G
LC1F265/4	[25]	[25]	LA9FH4H
LC1F330/4	[25]	[25]	LA9FJ4J
LC1F400/4	[25]	[25]	LA9FJ4J
LC1F500/4	[25]	[25]	LA9FK4K
LC1F630/4	[25]	[25]	LA9FL4L
LC1F780	[26]	—	LA9FX970 [26]
LC1F780/4	—	[27]	LA9FX971 [27]

Table 18.69: Vertical Mounting of 2 Contactors of Different Ratings [28]

Upper Contactor	Lower Contactor [29]	Mechanical Interlock Kit Cat. No.
LC1F185/4 or F225/4	LC1F115/4 or F150/4	LA9FG4F
LC1F265/4 or F330/4	LC1F115/4 or F150/4	LA9FH4F
LC1F265/4 or F330/4	LC1F185/4 or F225/4	LA9FH4G
LC1F400/4	LC1F115/4 or F150/4	LA9FJ4F
	LC1F185/4 or F225/4	LA9FJ4G
	LC1F265/4 or F330/4	LA9FJ4H
LC1F500/4	LC1F115/4 or F150/4	LA9FK4F
	LC1F185/4 or F225/4	LA9FK4G
	LC1F265/4 or F330/4	LA9FK4H
LC1F630/4 or F800	LC1F400/4	LA9FK4J
	LC1F115/4 or F150/4	LA9FL4F
	LC1F185/4 or F225/4	LA9FL4G
	LC1F265/4 or F330/4	LA9FL4H
	LC1F400/4	LA9FL4J
	LC1F500/4	LA9FL4K

TeSys F contactors: TeSys™ F Non-Reversing Contactors, page 18-12 and TeSys™ F Reversing Contactors, page 18-13
 TeSys F contactor accessories: TeSys™ D and F Accessories, page 18-16
 TeSys F overload relay accessories: TeSys F Overload Relay Accessories, page 18-22
 TeSys F replacement coils and parts: TeSys F Contact Kits, Arc Chambers, page 18-48, TeSys F AC Coils, page 18-44, and TeSys F DC Coils, page 18-47
 TeSys F dimensions: TeSys™ F Contactors, Dimensions, page 18-53, TeSys™ F Overload Relay Dimensions, page 18-61

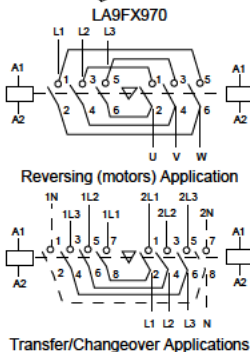

[25] Power connection to be assembled by the customer.
 [26] Double mechanical interlock with 2 mechanical links and 3 power connection bars.
 [27] Double mechanical interlock with 2 mechanical links and 4 power connection bars.
 [28] With identical or different numbers of poles.
 [29] Lower contactor must have equal or lesser current rating.

TeSys™ F Contactors

Table 18.70: Suppressor Blocks

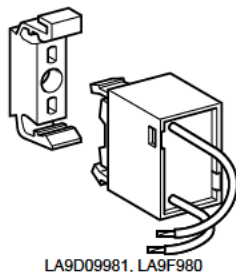

LA9D09981, LA9F980

Operating limit up to 220 V, 50/60 Hz coils		
Description	For Use with coils	Catalog Number
Suppressor block (clip-on mounting to coil)	LX1FF, FG, FH, F115, F150, F185, F225, F265, F330	LA9F980
	LX1FJ, FK, FL, FX, F400, F500, F630, F780, LX9FF, FG, FH, F115, F150, F185, F225, F265, F330	LA9D09980
Mounting bracket (for 35 mm DIN rail or panel mounting) for suppressor block		LA9D09981

Table 18.71: Lugs and Lug Kits [30]

Contactor Type LC1	Lug Kit Catalog Number Contactor Only	Cable Size AWG range	Overload Relay	Directly mounted to contactor	Lugs Required		Cable size AWG range	
				LC1*	Line side of contactor	Load side of overload	Line side of contactor	Load side of overload
F115	DZ2FF6	14 to 2/0	LR9F5*57 to F5*69, LR9F57 to F69	F115	3 each DZ2FF1	3 each DZ2FG1	14 to 2/0	6 to 3/0
F150, F185	DZ2FG6	6 to 3/0	LR9F5*57 to F5*71, LR9F57 to F71	F150 to F185	1 each DZ2FG6		6 to 3/0	
—	—	—	LR9F5*71, LR9F71	F225, F265	1 each DZ2FH6		6 to 300 MCM	
F225, F265, F330	DZ2FH6	6 to 300 MCM	LR9F7*75 to F7*79, LR9F75 to F79	F265 or F330	3 each DZ2FH1	—	6 to 300 MCM	4 to 500 MCM
F400	DZ2FJ6	4 to 500 MCM	LR9F7*75 to F7*81, LR9F75 to F81	F400	3 each DZ2FJ1	—	4 to 500 MCM	4 to 500 MCM
F500	DZ2FK6	2 x 2 to 600 MCM	LR9F7*75 to F7*81, LR9F75 to F81	F500	3 each DZ2FK1	—	2x2 to 600 MCM	4 to 500 MCM
F630, F800	DZ2FL6	3 x 2 to 600 MCM	LR9F7*81, LR9F81	F630	1 each DZ2FL1 DZ2FL2 DZ2FL3	1 each DZ2FR1	3x2 to 600 MCM	4 to 500 MCM
F780	DZ2FX6	4 x 1/0 to 750 MCM	—	—	—	—	—	—

Table 18.72: Lugs, 2- and 4-Pole [31]

Contactor Type LC1	Lug Kit Catalog Number	Qty. Required		AL/CU Cable Size
		2-Pole	4-Pole	
F115	DZ2FF1	4	8	14 to 2/0
F150, F185	DZ2FG1	4	8	6 to 3/0
F225, F265, F330	DZ2FH1	4	8	6 to 300 MCM
F400	DZ2FJ1	4	8	4 to 500 MCM
F500	DZ2FK1	4	8	2 X 2 to 600 MCM
F630	DZ2FL* [32]	[32]	[32]	3 X 2 to 600 MCM
F780	DZ2FX1	4	8	4 X 1/0 to 750 MCM

These clear plastic protective shrouds are an effective means to meet international touch-safe requirements for power terminals. They are designed to be used with power cables that have been bolted to the terminal.

NOTE: The protection shrouds do not attach to contactors or overloads using DZ2F lug kits.

Table 18.73: Power Terminal Protection Shrouds

For Use With 2-, 3-, And 4-pole Contactors	Number of Shrouds Per Set	Catalog Number
LC1F115	6	LA9F701
LC1F150, F185	6	LA9F702
LC1F225, F265, F330, F400 and F4002, F500 and F5002	6	LA9F703
LC1F630, F6302 and F800	6	LA9F704
LC1F1154	8	LA9F706
LC1F1504 and F1854	8	LA9F707
LC1F2254, F2654, F3304, F4004, F5004	8	LA9F708
LC1F6304	8	LA9F709

For contactors LC1F115, LC1F150, and LC1F185, an available touch-safe terminal block may be used in place of lugs for power connections.

Table 18.74: Insulated Terminal Blocks

For contactor type LC1	For overload relay LR9	Maximum Cable Size	Catalog Number
F115, F150, F185	F5*57, F5*63, F5*67, F5*69, F57, F63, F67, F69	300 MCM	LA9F103

TeSys F contactor accessories: TeSys™ D and F Accessories, page 18-16
 TeSys F overload relay accessories: TeSys F Overload Relay Accessories, page 18-22
 TeSys F replacement coils and parts: TeSys F Contact Kits, Arc Chambers, page 18-48, F AC, page 18-44, and TeSys F DC Coils, page 18-47
 TeSys F dimensions: TeSys™ F Contactors, Dimensions, page 18-53, TeSys™ F Overload Relay Dimensions, page 18-61

[30] Lug kits ending in the number 6 include 6 identical lugs. In some cases the LR9F overload relay mounted directly on the load side of an LC1F contactor will require a different size lug for your choice of contactor and overload. If the two sizes are different, order 3 of each size lug. Mounting hardware (screws, washers, and nuts) are provided with the contactors and overload relays, not with the lugs.
 [31] Lugs for LC1F contactors and overload relays must be ordered separately. Each kit consists of one lug. Mounting hardware (screws, washers, nuts) are provided with the contactors, not the lugs.
 [32] For 2-pole F630 contactors, order two DZ2FL1 (L1 and T2), and two DZ2FL3 (L2 and T1).
 For 4-pole F6304, order two DZ2FL1 (L1 and T4), four DZ2FL2 (L2, T2, L3, T3) and two DZ2FL3 (L4 and T1).

TeSys D Overload Relay Accessories

Table 18.75: Mounting Kits and Plates^[1]

Description	For use with overload relays	Cat. No.
Separate mounting kits for mounting to 35 mm DIN rail or for panel mounting with screws	LRD01-35 and LR3D01-35	LAD7B10
	LRD01-35 and LR3D01-35 for ring tongue terminals	LAD7B106
	LRD04L-32L, LR3D04L-32L, and LR9D01-32	LAD7B205
	LRD3•••, LR3D3•••, LR2D35••	LA7D3064
Mounting plates for screw mounting at 110 mm (4.3 in.) centers	LRD01-35, LR3D01-35, LR2D15••	DX1AP25
	LRD3•••, LR3D3•••, LR2D35••	LA7D902



LA7D901



LA7D03

Table 18.76: Accessories

Description	For use with	Standard Packaging	Catalog Number
Prewiring kit allows direct connection of the N.C. contact of relay LRD01-D32 or LR3D01-D32 to the contactor	LC1D09 to D18	10	LAD7C1
	LC1D25 to D38	10	LAD7C2
Stop button locking device	All relays except LRD01-D32, LR3D01-D32 and LR9D	10	LA7D901
Remote stop/tripping or electrical reset ^[2]	LRD01-D32, LRD3, LR3D01-D32, LR3D3	1	LAD703 ^[3]
	All relays except LRD01-D32, LR3D01-D31	1	LA7D03 ^[3]
Reset by flexible cable 500 mm (19.6 in.)	LRD01-D32, LRD3, LR3D3	1	LAD7305

Table 18.77: Control Circuit Voltages for LA7D03 and LAD703

Volts	12	24	48	110	220/230	380/400	415/440
AC 50/60 Hz	J ^[4]	B	E	F	M	Q	N
DC	J	B	E	F	M	—	—

TeSys F Overload Relay Accessories

Table 18.78: Mounting Plate for Overload Relay

For use with relays	Catalog Number
LR9F5•57, F5•63, F5•67, F5•69, F5•71, F57, F63, F67, F69, and F71	LA7F901
LR9F7•75, F7•79, F5•81, F75, F79, and F81	LA7F902



LA7F90•

These clear plastic protective shrouds are an effective means to meet international finger-safe requirements for power terminals. They are designed to be used with power cables that have been bolted to the terminal.

NOTE: Protection shrouds do not attach to contactors/overloads using DZ2F lug kits.

Table 18.79: Power Terminal Protection Shrouds, Single-Pole

For use with relays	Catalog Number
LR9F5•57, F57	LA9F701
LR9F5•63, F5•67, F5•69, F63, F67, F69	LA9F702
LR9F5•71, F71	LA9F705
LR9F7•75, F7•79, F7•81, F75, F79, F81	LA9F703

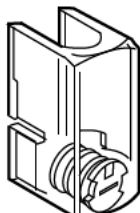

LA9F70•

Table 18.80: Power Terminal Protection Shrouds, 3-Pole

For use with relays	Catalog Number
LR9F5•57, F5•63, F5•67, F5•69, F57, F63, F67, F69	LA7F701
LR9F5•71, F71	LA7F702
LR9F7•75, F7•79, F7•81, F75, F79, F81	LA7F703

Table 18.81: Connection Accessories (for Mounting Overload Relays Beneath Reversing Contactors)^[5]

Application	For relays	For contactor	Set of 3 Busbars Catalog Number
	LR9F5•57, F5•63, F5•67, F5•69, F69, F71	LC1F115	LA7F401
	LR9F5•57, F5•63	LC1F150 and F185	LA7F402
	LR9F5•71, F71	LC1F185	LA7F407
	LR9F5•71, F71	LC1F225 and F265	LA7F403
	LR9F7•75, F5•79, F75, F79	LC1F225 to F400	LA7F404
	LR9F7•81, F81	LC1F400	LA7F404
	LR9F7•75, F7•79, F7•81, F75, F79, F81	LC1F500	LA7F405
	LR9F7•81, F81	LC1F630 and F800	LA7F406



LA7F701

Table 18.82: Marking Accessories

Description	Sold in units of	Catalog Number
Marker holder, snap-in	100	LA7D903

Main overload selection: TeSys D AC and DC Contactors, page 18-7 and TeSys™ F AC and DC Contactors, page 18-11

TeSys D dimensions: TeSys™ D Open Starter Dimensions, page 18-57 and TeSys™ D Thermal Overload Relay Dimensions, page 18-59

TeSys F dimensions: TeSys™ F Contactors, Dimensions, page 18-53, TeSys™ F Overload Relay Dimensions, page 18-61

TeSys T: see TeSys™ T Motor Management System, page 16-101

[1] When using mounting plates, separate mounting kits are also required.
 [3] Part number to be completed by adding coil voltage code, (for example, LAD703F).
 [4] Not available for LRD01-D32, LR3D01-D32.
 [5] Mounting plate required.

TeSys™ U Motor Starter

The TeSys U motor starter is integrated, making it simple to choose and install. It consists of a control unit snapped in a power base. TeSys U can be configured to fit specific applications as well. Optional accessories include a reverser, a current limiter, predictive maintenance options, and communication options. For detailed information about TeSys U, visit our website.



Selecting TeSys U Motor Starters in Three Steps

Table 18.83: Step 1. Select Power Base (Only two different bases up to 32 A)



Control Connection	Max. Current (A)	Maximum Horsepower Ratings						Self-Protected Starter Base Catalog Number
		Three-Phase				Single-Phase		
		200 V	230 V	460 V	575 V	115 V	230 V	
With non-removable screw terminations	12	3	3	7.5	10	1.5	2	LUB12
	32	10	10	20	25	2	5	LUB32
Without screw terminations	12	3	3	7.5	10	1.5	2	LUB120[1]
	32	10	10	20	25	2	5	LUB320[1]

Table 18.84: Step 2. Select Control Unit [2]

Setting Range (A)	Standard 3-phase Class 10 trip [3]	Advanced 3-phase Class 10 trip [3]	Advanced single-phase Class 10 trip [3]	Advanced 3-phase Class 20 trip [3]
0.15–0.6	LUCAX6●●	LUCBX6●●	LUCGX6●●	LUCDX6●●
0.3–1.4	LUCA1X●●	LUCB1X●●	LUCX1X●●	LUCD1X●●
1.25–5.0	LUCA05●●	LUCB05●●	LUCX05●●	LUCD05●●
3–12	LUCA12●●	LUCB12●●	LUCX12●●	LUCD12●●
4.5–18	LUCA18●●	LUCB18●●	LUCX18●●	LUCD18●●
8–32	LUCA32●●	LUCB32●●	LUCX32●●	LUCD32●●

Table 18.85: Voltage Codes

Volts	24	48–72	110–240
DC	BL[4]	—	—
AC	B	—	—
DC or AC	—	ES[5]	FU

Table 18.86: Step 3. Select Auxiliary Contacts (optional)

Terminals	Contact Indicates	Contact Normal Status	Contact State for Each Mode[6]							Catalog Number
			Off	Ready	Run	Short Circuit Trip	Overload Trip (Manual Reset)	Overload Trip (Remote/Auto Reset)[7]		
Auxiliary Contact Blocks										
Screw	Ready condition	N.O.	0	1	1	0	0	0	1	LUA1C11
	Fault condition	N.C.	1	1	1	0	0	1	1	
Screw	Ready condition	N.O.	0	1	1	0	0	0	1	LUA1C20
	Fault condition	N.O.	0	0	0	1	1	0	1	
Auxiliary Contact Function Modules										
Screw	Pole state	2 N.O.	0	0	1	0	0	0	1	LUFN20
Screw	Pole state	1 N.O. and 1 N.C.	0	1	1	0	0	1	1	LUFN11
Screw	Pole state	2 N.C.	1	1	0	0	1	1	1	LUFN02

Table 18.87: Accessories

Accessory	Quick Description	For details & selection, see
Current limiter	Increases the breaking capacity to 130 kA @ 460 V and to 65 kA @ 575 V	Line Phase Barrier, Reverser, page 18-25
Reverser	Stacked or side mounted (LU6MB0●●● only)	Line Phase Barrier, Reverser, page 18-25
Line phase barrier	Required for use as a self-protected combination starter (UL 508 Type E)	Line Phase Barrier, Reverser, page 18-25
Multifunction control unit	Has functions for monitoring and predictive maintenance	Line Phase Barrier, Reverser, page 18-25
Function modules	Fault differentiation, thermal overload, motor load indication	Line Phase Barrier, Reverser, page 18-25
Communication modules	Integrates into existing networks, major protocols are available	Communication Modules and Control Circuit Accessories, page 18-26
Soft starter + TeSys U	Use Altistart U01soft starter with TeSys U	Altistart Drive and TeSys U Motor Starter, page 18-42
Powerbus	Use TeSys U with a prewired system	Communication Modules and Control Circuit Accessories, page 18-26
Configuration and connection accessories	SoMove software, bus bar, external handle	GV2 Cabling Accessories—Bus Bars, page 18-26

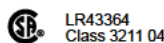
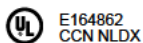

Accessories: Power Base and Plug-in Accessories, page 18-24 to Powerbus, page 18-26
 Dimensions: TeSys U Starter Dimensions, page 18-64
 Overload Relays: TeSys™ K Overload Relays, page 18-3
 Accessories: Aux Contact Blocks, page 18-14
 Dimensions: TeSys K Contactor Dimensions, page 18-63

[1] For use with reversing modules or communication modules with prewired connector
 [2] The control unit contains solid-state overload relay and control power source for TeSys U. For more details on the different control units, their functions, and placement on the power base, see Power Base and Plug-in Accessories, page 18-24
 [3] Complete the catalog number by adding appropriate code from Table 18 85 Voltage Codes, page 18-23 (for example, LUCAX6FU).
 [4] DC voltage with range of 0.90 to 1.10 of nominal.
 [5] 48–72 Vdc; 48 Vac
 [6] 1 indicates closed contact; 0 indicates open contact
 [7] Requires multifunction or advanced control unit plus fault differentiation module LUFDA10.

Control Units and Functions

Table 18.88: Control Units and Functions

Reference	Standard LUCA	LUCB	Advanced LUCC	LUCD	Multifunction LUCM
Protection type					
Class 10					
Class 20					
Class 5–30					
Single Phase: LUCC Class 10 only					
Protection functions					
Short circuit					
Over current					
Thermal overload					
Phase loss					
Phase imbalance					
Ground fault					
Underload, long start, jam					
Control functions					
Manual reset					
Automatic or local/remote reset					
Fault differentiation					
Thermal alarm					
Motor load display					
Fault history					
Alarm threshold adjustment					
Tripping test					
		= built-in the control unit			
		= works with the related function modules (see Line Phase Barrier, Reverser , page 18-25)			

Power Base and Plug-in Accessories

See below where to install accessories on the power base. Only one accessory can be installed in each location.

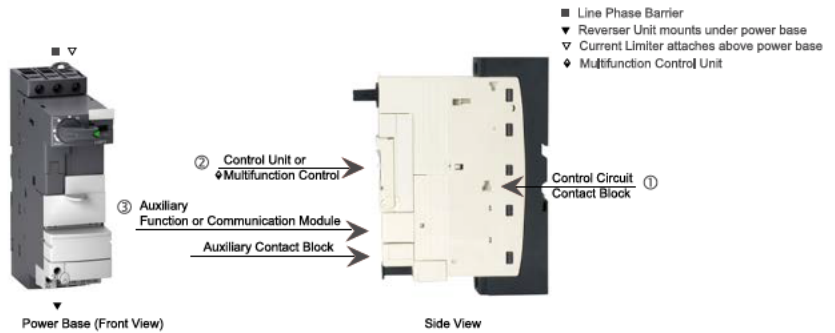

TeSys™ U Simple Motor Starter

Table 18.89: Line Phase Barrier (optional) [8]



Line Phase Barrier



Reverser Unit Assembled under the Power Base

Description	Cat. No.
Incoming line phase barrier to allow the TeSys U to be used as a self-protected combination starter according to UL508 Type E	LU9SP0

Table 18.90: Reverser

Control Connection	Max. Current (A)	Maximum Horsepower Ratings						Self-Protected Starter Base Catalog Number
		Three-Phase			Single-Phase			
		200 V	230 V	460 V	575 V	115 V	230 V	
With screw terminations	12	3	3	7.5	10	1.5	2	LU2B12[9]
	32	10	10	20	25	2	5	LU2B32[9]

Table 18.91: Select Control Unit Options [10][11]

Setting Range (A)	Standard Three-Phase Class 10 trip [12]	Advanced Three-Phase Class 10 trip [12]	Advanced Single-Phase Class 10 trip [12]	Advanced Three-Phase Class 20 trip [12]
0.15–0.6	LUCAX6●●	LUCBX6●●	LUCCX6●●	LUCDX6●●
0.3–1.4	LUCA1X●●	LUCB1X●●	LUCC1X●●	LUCD1X●●
1.25–5.0	LUCA05●●	LUCB05●●	LUCC05●●	LUCD05●●
3–12	LUCA12●●	LUCB12●●	LUCC12●●	LUCD12●●
4.5–18	LUCA18●●	LUCB18●●	LUCC18●●	LUCD18●●
8–32	LUCA32●●	LUCB32●●	LUCC32●●	LUCD32●●

Table 18.92: Voltage Codes

Volts	24	48–72	110–240
DC	BL [13][14]	—	—
AC	B	—	—
DC or AC	—	ES [15]	FU

Table 18.93: Reversing Modules for Field Addition

Mounting	Catalog No.	Wiring Adapter	
Beneath	LU2MB0	LU9MR1C	Note: For LU2MB0 and LU6MB0, voltage code required; must match control unit.
Beside	LU6MB0	LU9MR1	

Table 18.94: Current Limiter [16][17]

Accessory	Application	Technical Data	Mounting	Cat. No.
Current limiter/isolator	Additional current limiting aspects for the starter	130 kA at 460 V 65 kA at 575 V	Direct mounting to LUB● and LU2B●	LUALB1
Limiter cartridge	Replacement cartridge for LUALB1	130 kA at 460 V 65 kA at 575 V	—	LUALF1

Table 18.95: Control Unit Multifunction [16][18]

Setting Range (A)	Multifunction programmable
0.15–0.6	LUCMX6BL
0.3–1.4	LUCM1XBBL
1.25–5.0	LUCM05BBL
3–12	LUCM12BBL
4.5–18	LUCM18BBL
8–32	LUCM32BBL

Table 18.96: Function Modules [16][19]

Module	Description	For use with	Operation Requirements	Catalog Number
Fault differentiation with manual reset (thermal overload)	Provides indication between an overload trip and a short circuit trip.	Advanced control units only	24–250 Vac or Vdc (power from control unit)	LUFDH11
				LUFDA10
Thermal overload pre-alarm	Signals when the motor current reaches 1.05 of the full load setting on the control unit.	Advanced control units only	24–250 Vac or Vdc (power from control unit)	LUFW10
Motor load indication	Provides a signal proportional to the average currents in the three phases divided by the full load current setting of the control unit. The output corresponds to a load status of 0–2 times the full load setting of the control unit.	Advanced or multi-function control units	4–20 mA (requires separate 24 Vdc power supply)	LUFV2
Parallel wiring	Provides a convenient way to reduce control wiring and allow for connecting starters to a communications network by providing 24 Vdc for the starters.	Advanced or multi-function control units (24 Vdc only) and LU9BN11C or LU9MRC prewired connector	LU9G02 splitter box and PLC network	LUFC00



Control Unit Multifunction



Alarm Differentiation



Parallel Wiring



Motor Load Indicator

[8] See Power Base and Plug-in Accessories, page 18-24 for placement on the power base.

[9] Voltage code required.

[10] The control unit contains solid-state overload relay and control power source for TeSys U. For more details on the different control units, their functions, and placement on the power base see Power Base and Plug-in Accessories, page 18-24.

[11] Control units for 4.5–18 and 8–32 can be used only with 32 A rated power bases (LUB32, LUB320, and LU2B32).

[12] Complete the catalog number by adding the appropriate code from Table 18.92 Voltage Codes, page 18-25 (for example, LUCAX6FU).

[13] DC voltage with range of 0.90 to 1.10 of nominal.

[14] Voltage code to use for a power base with a communication module.

[15] 48–72 Vdc; 48 Vac

[16] See Power Base and Plug-in Accessories, page 18-24 for placement on the power base.

[17] Increases the breaking capacity of the motor starter.

[18] Offers motor management system capabilities. For more details see the LUCM on Communication Modules and Control Circuit Accessories, page 18-26

[19] Offers customization for specific application requirements.

Communication Modules and Control Circuit Accessories

Table 18.97: Communication Modules [20][21]



Module	Description	For use with	Operation Requirements	Catalog Number
AS-Interface Communication	Allows the TeSys U starter to be connected directly to the network using AS-Interface protocols.	Advanced or multi-function control units (24 Vdc only) and LU9BN11C or LU9MRC prewired connector	Requires separate 24 Vdc power supply and AS-Interface network	ASILUFC5
AS-Interface V2 Communication	Allows the TeSys U starter to be connected directly to the network using AS-Interface V2 protocols.	Advanced or multi-function control units (24 Vdc only) and LU9BN11C or LU9MRC prewired connector	Requires separate 24 Vdc power supply and AS-Interface V2 network	ASILUFC51
Modbus™ Communication Protocol	Allows the TeSys U starter to be connected directly to the network using Modbus protocols.	Advanced or multi-function control units (24 Vdc only) and LU9BN11C or LU9MRC prewired connector	Requires separate 24 Vdc power supply	LULC033
Advantys™ STB Communication	Allows the TeSys U starter to be connected to the network using the Advantys STB protocol	Advanced or multi-function control units (24 Vdc only) and LU9BN11L or LU9MRL prewired connector	Requires separate 24 Vdc power supply	LULC15
CANopen Communication	Allows the TeSys U starter to be connected to the network using the CANopen protocol	Advanced or multi-function control units (24 Vdc only) and LU9BN11L or LU9MRL prewired connector	Requires separate 24 Vdc power supply	LULC08
Beckoff Communication	Allows the TeSys U starter to be connected to the network using the Beckoff protocol	Advanced or multi-function control units (24 Vdc only) and LU9BN11L or LU9MRL prewired connector	Requires separate 24 Vdc power supply	LULC14
Profibus Communication	Allows the TeSys U starter to be connected to the network using the Profibus protocol	Advanced or multi-function control units (24 Vdc only) and LU9BN11L or LU9MRL prewired connector	Requires separate 24 Vdc power supply	LULC07
DeviceNet™ Communication	Allows the TeSys U starter to be connected to the network using the Device Net protocol	Advanced or multi-function control units (24 Vdc only) and LU9BN11L or LU9MRL prewired connector	Requires separate 24 Vdc power supply	LULC09

Table 18.98: Control Circuit Accessories [20]

Accessory	Application	Technical Data	Mounting	Catalog Number
Control circuit contact block	Switches control circuit power via LUB• handle (NEC430-74 compliance)	5 A at 600 Vac 5 A at 250 Vdc	Side mounting to LUB• and LU2B• only	LUA8E20
Through-the-door operating mechanism	Use to enclose TeSys LUB• only.	NEMA 1, 12, 3R, 4, 4X Black without trip indication	Kit	LU9APN43
		NEMA 1, 12, 3R, 4, 4X Red/Yellow without trip indication	Kit	LU9APN44
Control circuit filters	Use with electronic or triac output controllers	Up to 150 Vac max.	Directly to coil terminals	Non-reversing Reversing LUA4F11 LUA4F12
Pre-wire connector	Central control when using communication modules	See Table 18.97 Communication Modules, page 18-26 for usage.	Lower power terminals to communication module.	Non-reversing Reversing LU9BN11C LU9BN11L LU9MRL

Power Bus Bars

Table 18.99: TeSys U Cabling Accessories—Bus Bars

Description	Application	Pitch	Standard Pack	Catalog Number
3-Pole, 63 A Bus Bar	For feeding 2 TeSys U controllers	45	1	GV2G245
		54	1	GV2G254
		72	1	GV2G272
	For feeding 3 TeSys U controllers	45	1	GV2G345
		54	1	GV2G354
		72	1	GV2G372
	For feeding 4 TeSys U controllers	45	1	GV2G445
		54	1	GV2G454
		72	1	GV2G472
For feeding 5 TeSys U controllers	54	1	GV2G554	

Additional accessories and components are available, including:

- Mounting accessories
- Gateways
- Cabling accessories
- Magelis™ remote display unit

[20] See Power Base and Plug-in Accessories, page 18-24 for placement on the power base.

[21] Communication capabilities can be integrated into existing automation architecture via a variety of protocols.

1. Choose a base configuration

Table 18.100: Base Configurations ^{New!}

Motor Voltage (V)	Ratings		Max. Current (A)	Type 1/12/3R enclosure		Type 4/4X enclosure	
	Max. HP			Non-reversing starter	Reversing starter	Non-reversing starter	Reversing starter
	Single phase	Three-phase		Base Configuration Number	Base Configuration Number	Base Configuration Number	Base Configuration Number
115	1.5		12	LE1U16	LE2U16	LE1U19	LE2U19
230	2						
200		3					
230		3					
460		7.5					
575		10					
115	2		32	LE1U36	LE2U36	LE1U39	LE2U39
230	5						
200		10					
230		10					
460		20					
575		25					

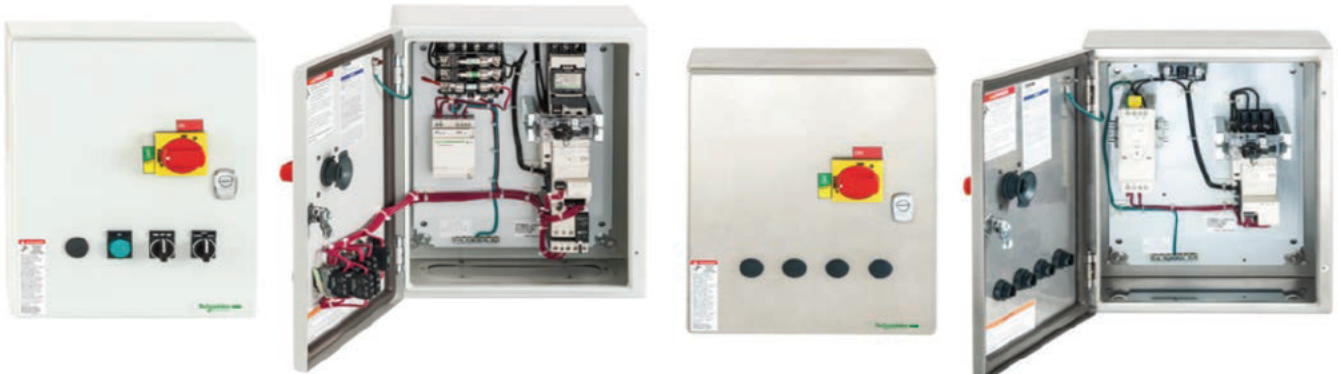

Type 1/12/3R enclosure

Type 4/4X enclosure

2. Choose Thermal Overload Relay (Plug-in Control Unit)



The thermal overload relay is a control unit that plugs into the TeSys U starter. No tool is needed to install or remove the control unit.

If you do not wish to select the thermal overload relay at this time, select Thermal Overload Relay Type codes N1 or N3 in function of the motor configuration (single phase or 3-phase) in [Thermal Overload Protection Types, page 18-28](#). A thermal overload relay can be selected and ordered later on (independently) before installation.

In order to select a thermal overload relay, you must follow the next 2 steps. First, select the thermal overload protection type code in [Thermal Overload Protection Types, page 18-28](#). Secondly, select the full load amperage code in [Full Load Amperage Code, page 18-28](#).

2.1 Choose the thermal overload protection type

Table 18.101: Thermal Overload Protection Types

	Advanced Control Unit				Multifunction Control Unit		No Control Unit (Ordered later on independently)	
							Single Phase	3-Phase
Thermal Overload Protection Type Code	A ▲	B ▲	C ▲	D ▲	N1	N3		
Protection Type								
Single phase, Class 10	■							
3-phase, Class 10		■						
3-phase, Class 20			■					
3-phase, Selectable Class 5–30				■				
Protection Functions								
Short circuit	■	■	■	■				
Over current	■	■	■	■				
Thermal overload	■	■	■	■				
Phase loss		■	■	■				
Phase imbalance		■	■	■				
Ground fault	■	■	■	■				
Underload, long start, jam	◆	◆	◆	■				
Control Functions								
Automatic or local/remote reset	◆	◆	◆	■				
Fault differentiation	◆	◆	◆	■				
Thermal alarm	◆	◆	◆	■				
Motor load display	◆	◆	◆	■				
Fault history				■				
Alarm threshold adjustment				■				
Tripping test	■	■	■	■				

▲ Complete the Thermal Overload Relay Selection by adding the full load amperage code after the thermal overload protection type code.
 ■ Built-in Control Unit.
 ◆ Available when combined with appropriate Function module.

2.2 Choose the Motor Full Load Amperage

Table 18.102: Full Load Amperage Code

Full Load Amperage Setting Range (A)	Full Load Amperage Code
0.15–0.6	A
0.3–1.4	B
1.25–5.0	C
3–12	D
4.5–18	E
8–32	F

3. Choose the Control Power Source

Table 18.103: Control Power Source Code

Control Circuit Source	System Type	Motor Voltage		Control Voltage		Control Power Source Code		
		Voltage	Voltage Type	Voltage	Voltage Type			
Common Control	Single Phase	120	AC	120	AC	G7		
		240	AC	240	AC	U7		
	Three-Phase	208	AC	208	AC	LE7		
		240	AC	240	AC	U7		
Separate Control	Single Phase	120	AC	24	AC	B7 [22]		
		120	AC	24	DC	BD [22]		
		120	AC	120	AC	G7 [22]		
		240	AC	24	AC	B7 [22]		
		240	AC	24	DC	BD [22]		
		240	AC	120	AC	G7 [22]		
	Three-Phase	208	AC	24	AC	B7 [22]		
		208	AC	24	DC	BD [22]		
		208	AC	120	AC	G7 [22]		
		240	AC	24	AC	B7 [22]		
		240	AC	24	DC	BD [22]		
		240	AC	120	AC	G7 [22]		
		480	AC	24	AC	B7 [22]		
		480	AC	24	DC	BD [22]		
		480	AC	120	AC	G7 [22]		
		600	AC	24	AC	B7 [23]		
		600	AC	24	DC	BD [23]		
		600	AC	120	AC	G7 [23]		
		Factory Installed Control Power Transformer [24]	Single Phase	120	AC	24	AC	V89
				240	AC	120	AC	V80
240	AC			24	AC	V82		
208	AC			24	AC	V90		
Three-Phase	208		AC	120	AC	V84		
	240		AC	24	AC	V82		
	240		AC	120	AC	V80		
	480		AC	24	AC	V83		
	480		AC	120	AC	V81		
	600		AC	24	AC	V91		
	600		AC	120	AC	V86		
	Factory Installed Power Supply [25]		Single Phase	120	AC	24	DC	BD1
240		AC		24	DC	BD2		
208		AC		24	DC	BD2		
Three-Phase		240	AC	24	DC	BD2		
		480	AC	24	DC	BD2		
		600	AC	24	DC	BD6		

4. Choose Communication Type

If you do not need communication capabilities, select communication code N.

If a Communication protocol is selected, Control Voltage must be 24 Vdc (Control Power Source Codes BD, BD1, BD2 or BD6 only. Refer to [Control Power Source Code](#), page 18-29).

If additional I/O is needed with communication, select communication code N in [Table 18.104 Communication Code](#), page 18-29 and choose between Forms W10, W11, W12, W13 and W14 from [Distributed 6 Input/6 Output Modicon STB with Communication Forms](#), page 18-31.

Table 18.104: Communication Code

Communication Protocol	Communication Code
Modbus	M
Modbus TCP/IP	E
CANopen	C
DeviceNet	D
Beckhoff	B
Profibus	P
Advantys STB	A
AS-interface	J
AS-interface V2	K
No Communication	N

5. Choose Factory Modifications

When choosing Factory modifications, the Form code must be added at the end of the catalog number. If several forms are selected, they must be arranged in alphabetical order. There are two types of Forms available: abbreviated forms and standard forms.

[22] Form S must be added at the end of the catalog number.

[23] Form S6 must be added at the end of the catalog number. Current limiter is provided and factory installed.

[24] Two fuses in primary and one fuse in secondary provided as standard.

[25] Fuse holder with 2 fuses provided as standard.

5.1 Abbreviated Forms

Abbreviated forms are defined combinations of the most commonly ordered standard forms and are part of the profiled configurations with short lead time. For example, abbreviated form CP1 is a combination of standard forms C and P51.

Abbreviated forms cannot be mixed with other standard forms, with the exceptions of forms S and S6. If your combination of forms is not available as an abbreviated form, use only standard forms and arrange them in alphabetical order. For example, LE1U16BDG7NCP1S is a valid catalog number with the abbreviated form CP1. If you want to add standard Form P68, the valid catalog number becomes LE1U16BDG7NCP51P68S. LE1U16BDG7NCP1P68S is invalid because abbreviated form CP1 cannot be used with standard form P68.

Table 18.105: Abbreviated Forms

Factory Modifications	Form
Hand/Off/Auto Selector Switch + Red ON LED Standard Pilot Light	CP1
Hand/Off/Auto Selector Switch + Green ON LED Standard Pilot Light	CP2
Hand/Off/Auto Selector Switch + Red ON LED Standard Pilot Light + Green OFF LED Standard Pilot Light	C12
Hand/Off/Auto Selector Switch + Green ON LED Standard Pilot Light + Red OFF LED Standard Pilot Light	C21
Start/Stop Push Buttons + Red ON LED Standard Pilot Light	AP1
Start/Stop Push Buttons + Green ON LED Standard Pilot Light	AP2
Start/Stop Push Buttons + Red ON LED Standard Pilot Light + Green OFF LED Standard Pilot Light	A12
Start/Stop Push Buttons + Green ON LED Standard Pilot Light + Red OFF LED Standard Pilot Light	A21
ON/OFF Selector Switch + Red ON LED Standard Pilot Light	C61
ON/OFF Selector Switch + Green ON LED Standard Pilot Light	C62
ON/OFF Selector Switch + Red ON LED Standard Pilot Light + Green OFF LED Standard Pilot Light	C66
ON/OFF Selector Switch + Green ON LED Standard Pilot Light + Red OFF LED Standard Pilot Light	C67
Red ON LED Standard Pilot Light + Green OFF LED Standard Pilot Light	P12
Green ON LED Standard Pilot Light + Red OFF LED Standard Pilot Light	P21

5.2 Standard Forms

Table 18.106: Push Button Forms

Factory Modifications	Form
Start/Stop	A
Forward/Reverse/Stop	A1
ON/OFF	A3
Miscellaneous	A11
Stop	A13
Start Push Button + Stop Mushroom Head	A22
Emergency Stop Mushroom Head	A31
Turn-To-Release Emergency Stop Mushroom Head	A32

Table 18.107: Selector Switch Forms

Factory Modifications	Form
Hand/Off/Auto	C
Start/Stop	C1
ON/Auto	C2
ON/OFF	C6
Hand/Auto	C8
Forward/OFF/Reverse	C14
Forward/Reverse	C20
Three position	C34
Two position	C35
Keyed Hand/Off/Auto	C36
Keyed Start/Stop	C37
Keyed ON/Auto	C38
Keyed ON/OFF	C39
Keyed Forward/Off/Reverse	C43
Keyed Forward/Reverse	C47

Self-Protected Combination Starters
Table 18.108: 22 mm Standard LED Pilot Light Forms

Factory Modifications	Form
Red ON	P51
Green OFF	P52
White — Not Factory wired	P54
Blue — Not Factory wired	P56
Amber Overload Trip	P68
Yellow SSC Trip	P69
Red OFF	P91
Green ON	P92
Green Forward/Reverse	P95
Red Forward/Reverse	P96

Table 18.109: 22 mm Push-to-Test LED Pilot Light Forms

Factory Modifications	Form
Red ON	P42
Red OFF	P43
Green ON	P45
Green OFF	P46
Blue — Not Factory wired	P66
White — Not Factory wired	P67
Green Forward/Reverse	P79
Red Forward/Reverse	P80
Amber Overload Trip	P88
Yellow SSC Trip	P89

Table 18.110: Separate Control Forms

Factory Modifications	Form
Separate Control for starters with line voltage less or equal to 480 V	S
Separate Control for starters with line voltage equal to 600 V — Current Limiter is factory installed.	S6

Table 18.111: Additional Capacity Forms

Factory Modifications	Form
50 VA additional capacity	T10
100 VA additional capacity	T11

NOTE: Fuses are provided. Two fuses in primary and one fuse in secondary.

Table 18.112: Auxiliary Contact Forms

Factory Modifications	Form
2 N.O.	U8
1 N.O. and 1 N.C.	U9
2 N.C.	U10
1 N.C. fault signaling contact and 1 N.O. contact indicating starter is in "ready" state	U6
1 N.O. fault signaling contact and 1 N.O. contact indicating starter is in "ready" state	U7

Table 18.113: Auxiliary Relay Forms

Factory Modifications	Form
4 poles screw clamp Control Relay — 4 N.O.	R1740
4 poles screw clamp Control Relay — 3 N.O. and 1 N.C.	R1731
4 poles screw clamp Control Relay — 2 N.O. and 2 N.C.	R1722
Programmable Timer Relay	K1070

Table 18.114: Enclosure Forms

Factory Modifications	Form
Oversized enclosure — Only available for Type 1/12/3R	G28
Plain Blank Door — No covered pre-stamped holes	G30

Table 18.115: Miscellaneous Forms

Factory Modifications	Form
Nameplate — 2"x1/2" screwed	A241
Nameplate — 3"x1" screwed	A242
Unwired Terminal Block	G50 ^[26]
Wired Terminal Block	G56 ^[26] / ^[27]
Wire Markers	G105
Padlock Attachment	G122
Transient Suppressor	U11
Black P65 through the Door Rotary Disconnect Handle	G40
Special Factory Orders	SPL
Customer Control Wiring	Y217
Solid Neutral Terminal Block	N

Table 18.116: Increase Short Circuit Current Rating Forms

Factory Modifications	Form
130 kA @480 V — Current Limiter factory installed	Y1261

[26] Add number of terminal block points required. Number must be in increments of 5.

[27] Wiring diagram must be provided by customer.

Table 18.117: Soft Starter Forms^[28]

Factory Modifications	Form
Motor FLA < 6A	H1
6 < Motor FLA < 9A	H2
9 < Motor FLA < 12A	H3
12 < Motor FLA < 22A	H4
22 < Motor FLA < 32A	H5

Table 18.118: Distributed 6 Input/6 Output Modicon STB with Communication Forms ^[29]

Factory Modifications	Form
DeviceNet Bus	W10
Modbus TCP Bus	W11
Ethernet P Bus	W12
CANOpen Bus	W13
Profibus Bus	W14

Table 18.119: Starter Status Indication Forms

Factory Modifications	Form
Fault Differentiation Module — Manual Reset	U1
Fault Differentiation Module — Automatic or remote reset	U2
Thermal Overload Alarm Module	U3
Motor Load Indication Module	U4

TeSys H™ Ultra Compact Starters

TeSys H ultra compact motor starters are extremely compact motor starters for asynchronous motors (AC53a utilization category) and resistive loads (AC51 utilization category). With up to 75% space savings, the 22.5 mm wide starter maintains that width even for a reversing starter! An available safety version features embedded Safe Torque Off and is SIL3 according to IEC 61508-1 and Ple according to ISO 13849-1. TeSys H is ideal for industries such as food and beverage, logistics, and durable goods.

Table 18.120: TeSys H Ultra Compact Motor Starters

Non-Reversing					
Maximum HP Ratings			Current Setting Range (A)		Catalog Number ^{[30][31]}
200 V	230 V	460 V	Inductive AC53a	Resistive AC51	
1/2	1/2	1	0.18-2.4	0.18-2.4	LZ1H2X4
1	1.5	3	1.5-6.5	1.5-9.0	LZ1H6X5
Reversing					
Maximum HP Ratings			Current Setting Range (A)		Catalog Number ^{[30][31]}
200 V	230 V	460 V	Inductive AC53a	Resistive AC51	
1/2	1/2	1	0.18-2.4	-	LZ2H2X4
1	1.5	3	1.5-6.5	-	LZ2H6X5

Table 18.121: TeSys H Ultra Compact Safety Motor Starters (SIL3)

Non-Reversing					
Maximum HP Ratings			Current Setting Range (A)		Catalog Number ^{[30][31]}
200 V	230 V	460 V	Inductive AC53a	Resistive AC51	
1/2	1/2	1	0.18-2.4	0.18-2.4	LZ7H2X4
1	1.5	3	1.5-6.5	1.5-9.0	LZ7H6X5
Reversing					
Maximum HP Ratings			Current Setting Range (A)		Catalog Number ^{[30][31]}
200 V	230 V	460 V	Inductive AC53a	Resistive AC51	
1/2	1/2	1	0.18-2.4	-	LZ8H2X4
1	1.5	3	1.5-6.5	-	LZ8H6X5

Table 18.122: TeSys H Voltage Codes

24 Vdc	110-230 Vac (50/60Hz)
BD	FU



TeSys H™ Ultra Compact Starter



TeSys H Ultra Compact Safety Starter

[28] Motor Voltage must be equal to or less than 480 Vac and Control Voltage must be 24 Vdc (Control Power Source Codes BD, BD1, or BD2 only). Refer to [Control Power Source Code](#), page 18-29.

[29] Distributed I/O Modicon STB is factory wired.

[30] Complete the catalog number by adding the voltage code from [TeSys H Voltage Codes](#), page 18-32. For example, LZ1H2X4 becomes LZ1H2X4BD.

[31] For spring terminals, add 3 to the catalog number prior to adding the voltage code. For example, LZ1H2X4BD becomes LZ1H2X43BD.

TeSys™ GV Family

The TeSys GV family of products are 3-pole, horsepower rated, UL 508 listed manual starters. They include a manual disconnect, class 10 ambient-compensated thermal overload relay, and instantaneous, magnetic trip mechanism in one compact unit.

Any GV manual starter can be used alone for local manual control of a motor with individual full-load currents up to 220 A. The GV products may also be used in group motor installations in accordance with National Electric Code article 430-53. Group motor installations give you greater panel density for smaller size and require fewer parts and less wiring for installation when compared to conventional panel designs.

The GV2P and GV3P products also have an additional UL508 Type E rating as a stand-alone, self-protected manual combination starter. The UL508 Type E rating requires the addition of line side insulating barrier GV2GH7 for the GV2P or a GV3G66 line side insulating barrier and a GVAM11 short circuit signaling contact for the GV3P. The GV2P and GV3P self-protected manual combination starters may also be combined with specific size contactors from the LC1D product family for a UL508 Type F combination starter construction. These products have a UL-listed short circuit current rating from 10–100 kA depending on application size and voltage. Refer to the Motor Control Solutions for the North American Market data bulletin (8536DB0901) for more information.



GV2ME

Table 18.123: GV2, GV3

Thermal Setting (A)	Maximum Horsepower Ratings								Group Motor Applications Max. Fuse or Circuit Breaker	GV2ME push button [32] Catalog Number	GV2/3P rotary handle Catalog Number
	Single-Phase			Three-Phase							
	115 V	200 V	230 V	115 V	200 V	230 V	460 V	575 V			
0.10–0.16	—	—	—	—	—	—	—	—	450 A	GV2ME01	GV2P01
0.16–0.25	—	—	—	—	—	—	—	—	450 A	GV2ME02	GV2P02
0.25–0.40	—	—	—	—	—	—	—	—	450 A	GV2ME03	GV2P03
0.40–0.63	—	—	—	—	—	—	—	—	450 A	GV2ME04	GV2P04
0.63–1	—	—	—	—	—	—	—	1/2	450 A	GV2ME05	GV2P05
1–1.6	—	—	1/10	—	—	—	3/4	3/4	450 A	GV2ME06	GV2P06
1.6–2.5	—	1/6	1/6	—	1/2	1/2	1	1.5	450 A	GV2ME07	GV2P07
2.5–4	1/8	1/4	1/3	—	3/4	3/4	2	3	450 A	GV2ME08	GV2P08
4–6.3	1/4	1/2	1/2	3/4	1	1.5	3	5	450 A	GV2ME10	GV2P10
6–10	1/2	1	1.5	1	2	3	5	7.5	450 A	GV2ME14	GV2P14
9–14	3/4	2	2	2	3	3	10	10	450 A	GV2ME16	GV2P16
13–18	1	2	3	2	5	5	10	15	450 A	GV2ME20	GV2P20
17–23	1.5	3	3	3	5	7.5	15	20	450 A	GV2ME21	GV2P21
20–25	2	—	—	—	7.5	7.5	15	20	450 A	GV2ME22	GV2P22
24–32	2	5	5	5	7.5	10	20	25	450 A	GV2ME32	GV2P32
9–13	1/2	—	1.5	—	3	3	7.5	10	—	—	GV3P13
12–18	3/4	—	2	—	3	5	7.5	10	—	—	GV3P18
17–25	1.5	—	3	—	5	7.5	15	20	—	—	GV3P25
23–32	2	—	3	—	7.5	7.5	20	25	—	—	GV3P32
30–40	3	—	5	—	10	10	25	30	—	—	GV3P40
37–50	3	—	7.5	—	10	10	30	40	—	—	GV3P50
48–65	3	—	10	—	15	15	40	50	—	—	GV3P65



GV2P



GV3P

Table 18.124: GV7

Thermal Setting (A)	Maximum Three-Phase Horsepower Ratings				Toggle Operator	
	200 V	230 V	460 V	575 V	Standard Interrupt Catalog No.	High Interrupt Catalog No.
12–20	—	5	10	15	GV7RE20	GV7RS20
15–25	—	7.5	15	20	GV7RE25	GV7RS25
25–40	—	10	30	30	GV7RE40	GV7RS40
30–50	—	15	30	40	GV7RE50	GV7RS50
48–80	—	30	60	75	GV7RE80	GV7RS80
60–100	—	30	75	100	GV7RE100	GV7RS100
90–150	—	50	100	150	GV7RE150	GV7RS150
132–220	—	75	150	200	GV7RE220	GV7RS220

Accessories: TeSys™ GV2, GV3, GV7 Manual Starters and Protectors, page 18-37
Dimensions: TeSys Manual Starters and Protectors, page 18-66 and TeSys GV7 Manual Starters and Protectors, page 18-69



GV7RE20

[32] For spring terminals add 3 to the catalog number (for example, GV2ME013). GV2ME32 is not available with spring terminals. For ring terminals, add 6.

Motor Protector Circuit Breakers

Listed to UL 60947-4-1, these manual starters provide built-in thermal and magnetic protection.

Table 18.125: PowerPact™ Electronic Motor Protector Circuit Breakers (Manual Starters) ^{New!}

Electronic Trip Unit Type	Frame	Sensor Rating	Trip Unit	Full Load Ampere Rating (FLA)	Isd (x FLA)	G Interrupting	J Interrupting	L Interrupting	R Interrupting
						Cat. No.	Cat. No.	Cat. No.	Cat. No.
Standard [33]	H-Frame	30	2.2 M	14-25	5-13 x FLA	HGL36030M38X	HJL36030M38X	HLL36030M38X	HRL36030M38X
		50		14-42	5-13 x FLA	HGL36050M38X	HJL36050M38X	HLL36050M38X	HRL36050M38X
		100		30-80	5-13 x FLA	HGL36100M38X	HJL36100M38X	HLL36100M38X	HRL36100M38X
		150		58-130	5-13 x FLA	HGL36150M38X	HJL36150M38X	HLL36150M38X	HRL36150M38X
	L-Frame	250	2.3 M	114-217	5-13 x FLA	JGL36250M38X	JJL36250M38X	JLL36250M38X	JRL36250M38X
		400		190-348	5-13 x FLA	LGL36400M38X	LJL36400M38X	LLL36400M38X	LRL36400M38X
		600		312-520	5-13 x FLA	LGL36600M38X	LJL36600M38X	LLL36600M38X	LRL36600M38X

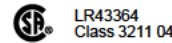
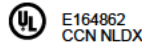

TeSys™ GV2 Accessories and Enclosures

Table 18.126: GV2 Mounting Accessories

Description	Application	Standard Pack [34]	Catalog Number
Common mounting plate	For GV2 plus any 3-pole LC1D09 thru LC1D25 contactor (supplied with GV1G02 connector)	1	GK2AF01
Adapter plate	For screw mounting of GV2M	10	GV2AF02
Combination block	Interconnect for GV2 plus any 3-pole LC1K or LP1K contactor	10	GV2AF01
	Interconnect GV2 and LC1D09 thru D32	10	GV2AF3
	Interconnect GV2 and LC1D09 thru D32 mounted on LAD31	10	GV2AF4
7.5 mm compensation plate	To allow mounting of GV2M and GV2P on a common bus bar	10	GV1F03
Mounting plate	For mounting GV2ME or GV2P and contactor LC1D09 thru D32	10	LAD31
		10	LAD311

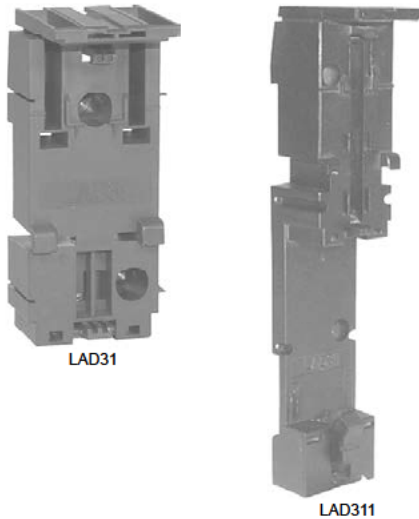

Table 18.127: GV2 Cabling Accessories—Bus Bars

Description	Application	Pitch	Standard Pack [34]	Catalog Number
3-Pole, 63 A Bus Bar	For feeding 2 GV2 starters	45	1	GV2G245
		54	1	GV2G254
		72	1	GV2G272
	For feeding 3 GV2 starters	45	1	GV2G345
		54	1	GV2G354
	For feeding 4 GV2 starters	45	1	GV2G445
		54	1	GV2G454
	For feeding 5 GV2 starters	72	1	GV2G472
		54	1	GV2G554

Table 18.128: GV2 Other Cabling Accessories

Description	Application	Standard Pack [34]	Catalog Number
Terminal blocks	Top feed for use with bus bars	1	GV1G09
	Bottom feed, to be used with bus bars; can be fitted with GV1L3 current limiter	1	GV2G05
Protective end cover	To cover unused bus bar outlets	5	GV1G10
3-pole flexible connector	For connecting a GV2 to an LC1D09 thru D25 contactor	10	GV1G02
Incoming line spacer	For GV2P when used in UL 508 Type E applications [35]	1	GV2GH7

Table 18.129: GV2 Other Accessories

Description	Application	Standard Pack [34]	Catalog Number
Visible isolation block—GV2P	Front mounting, 3-pole visible isolation on incoming side of GV2P	1	GV2AK00
Current limiter—GV2	Increases interrupt capacity when attached to GV2ME or GV2P	1	GV1L3
Through-the-door operating mechanism kits	NEMA 1, 12, Black with trip indication, for use with GV2P	1	GV2APN01
	NEMA 1, 12, Red/Yellow with trip indication, for use with GV2P	1	GV2APN02
	NEMA 3R, 4, 4X, Red/Yellow without trip indication, for use with GV2P	1	GV2APN04
Angle bracket	Operating mechanism support shaft for deep enclosures (≥ 250 mm), for use with GV2P	1	GVAPK11
Mounting bracket	Mounting bracket for installing GV2P operating mechanism	1	GVAPH02
Operating mechanism short shaft	One-piece short shaft for installing operating mechanisms in shallow enclosures, for use with GV2P, GV3P and TeSys U	1	GVAPA2
SoLink non-reversing communications link	Connection module for directly mounted GV2 and TeSys D contactor to PLC	5	LAD5C11
SoLink reversing communications link	Connection module for directly mounted GV2 and reversing TeSys D contactor to PLC	3	LAD5C12
Laser tool	Laser tool for installing through-the-door kits	1	GVAPL01

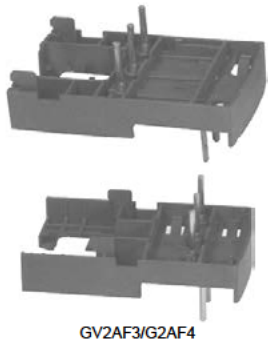

[33] The standard trip unit offers Class 5, 10, and 20 and phase unbalance or phase loss protection.

[34] Orders must specify multiples of quantities listed.

[35] Cannot be used with front-mounted auxiliary contact block.

Table 18.130: GV2 Enclosures

Description	Listing	Mounting	Enclosure Rating	Max. Side Mounting Aux. Contacts		Catalog Number
				Left Side	Right Side	
Enclosures for GV2ME with or without accessories	CSA Listed. Not UL Listed.	Surface mounting	NEMA 1, P41	1	1	GV2MC01
			NEMA 12/4, P55	1	1	GV2MC02
		Flush mounting	NEMA 1, P41	1	1	GV2MP01
			NEMA 12/4, P55	1	1	GV2MP02
		Flush mounting, front face reduced	NEMA 1, P41	0	1	GV2MP03
			NEMA 12/4, P55	0	1	GV2MP04

Table 18.131: GV2 Enclosures Accessories

Description	Type	Standard Pack ^[36]	Catalog Number	
Padlocking device for GV2M (when padlocked, starter is automatically in Off position)	—	1	GV2V01	
Mushroom head stop push button (40 mm, red) ^[37]	Spring return	1	GV2K011	
	Latching	Key release (Ronis key no. 455)	1	GV2K021
		Turn to Release	1	GV2K031
Latching / Padlockable Turn to Release		1	GV2K04	
Sealing kit	For enclosures GV2MC01 and GV2MP01	10	GV2E01	
Pilot Light (neon)	110 V	Green	10	GV2SN13
	110 V	Red	10	GV2SN14
	110 V	Orange	10	GV2SN15
	110 V	White	10	GV2SN17
	220/240 V	Green	10	GV2SN23
	220/240 V	Red	10	GV2SN24
	220/240 V	Orange	10	GV2SN25
	220/240 V	White	10	GV2SN27
	380/440 V	Green	10	GV2SN33
	380/440 V	Red	10	GV2SN34
	380/440 V	Orange	10	GV2SN35
380/440 V	White	10	GV2SN37	

[36] Orders must specify multiples of quantities listed.

[37] Supplied with P55 sealing kit.

Voltage Trips

Table 18.132: Voltage Trips



GVAU116

Only one trip or fault signaling contact can be installed per GV2/GV3 device.

Description	Characteristics	Voltage	Frequency	Cat. No. ^[38]
Voltage trips GV2 or GV3P	Undervoltage or Shunt trip (external mounting, 1 block right side only)	24 V	50 Hz	GVA●025
			60 Hz	GVA●026
		48 V	50 Hz	GVA●055
			60 Hz	GVA●056
		100–110 V	50/60 Hz	GVA●107
		110–115 V	50 Hz	GVA●115
			60 Hz	GVA●116
		120–127 V	50 Hz	GVA●125
		127 V	60 Hz	GVA●115
		200 V	50 Hz	GVA●207
		200–220 V	60 Hz	GVA●207
			50 Hz	GVA●225
		220–240 V	60 Hz	GVA●226
			50 Hz	GVA●385
		380–400 V	60 Hz	GVA●386
			50 Hz	GVA●415
		415–440 V	50 Hz	GVA●415
		415 V	60 Hz	GVA●416
440 V	60 Hz	GVA●385		
480 V	60 Hz	GVA●415		
500 V	50 Hz	GVA●505		
600 V	60 Hz	GVA●505		

Table 18.133: Voltage Trips—Technical Data (GV2AU, GV2AS)

Rated Voltage—660 Vac					
Model	Inrush	Sealed	Pick-Up Voltage	Drop-Out Voltage	Operating Time ^[39]
GVAU	12 VA / 8 W	3.5 VA / 1.1 W	0.8–1.1	0.35–0.7	10–15 ms
GVAS	14 VA / 10.5 W	5 VA / 1.6 W	0.7–1.1	0.2–0.75	10–15 ms

Table 18.134: Auxiliary Contact Blocks^[40]



GVAE11

Description	Mounting Location	Max. No. of Blocks	Contact Type	Sold in lots of	Cat. No.
Instantaneous auxiliary contacts GV2 or GV3P	Front ^{[41][42]}	1	N.O. or N.C. ^[43]	1	GVAE1
			N.O. + N.C.	10	GVAE11 ^[44]
	N.O. + N.O.		1	GVAE20 ^[44]	
Fault signaling contact + instantaneous auxiliary contact GV2 or GV3P	Left Hand Side	2	N.O. + N.C.	1	GVAN11 ^[44]
			N.O. + N.O.	1	GVAN20 ^[44]
			N.O. (fault) + N.O.	1	GVAD1010
				1	GVAD1001
N.C. (fault) + N.O.	1	GVAD0110			
	1	GVAD0101			
Short circuit signaling contact GV2 or GV3P	Left Hand Side	1	SPDT	1	GVAM11

Table 18.135: GV3P Accessories

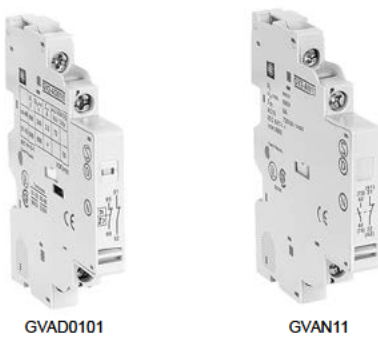

GVAD0101

GVAN11

Accessory	Application / Use With	Standard Pack	Cat. No.
Through-the-door operating mechanism kits	NEMA 1, 12, Black with trip indication, for use with GV3P	1	GV3APN01
	NEMA 1, 12, Red/Yellow, with trip indication, for use with GV3P	1	GV3APN02
	NEMA 3R, 4, 4X Red/Yellow without trip indication, for use with GV3P	1	GV3APN04
Angle bracket	Operating mechanism support shaft for deep enclosures (≥ 300 mm), for use with GV3P	1	GVAPK12
Mounting bracket	Mounting bracket for installing GV3P operating mechanism	1	GVAPH03
3-pole, 115 A busbar	For feeding 2 GV3P starters, 64 mm pitch	1	GV3G264
	For feeding 3 GV3P starters, 64 mm pitch	1	GV3G364
Incoming line spacer	Line spacer for GV3P when used in UL 508 Type E applications. One spacer required on line side.	1	GV3G66
P 20 cover	P20 protective cover for ring tongue versions of GV3P and 3-pole TeSys D Everlink contactors. Two covers required for line and load side.	1	LAD96570
Padlocking device	For use with up to 4 padlocks (not supplied). Ø 6 mm shank maximum	1	GV2V03
Operating mechanism short shaft	One-piece short shaft for installing operating mechanisms in shallow enclosures, for use with GV2P, GV3P and TeSys U	1	GVAPA2
SoLink non-reversing communications link	Connection module for directly mounted GV3 and TeSys D contactor to PLC	5	LAD5C31
SoLink reversing communications link	Connection module for directly mounted GV3 and reversing TeSys D contactor to PLC	3	LAD5C32
Laser tool	Laser tool for installing through-the-door kits	1	GVAPL01
S-shaped busbar	For connecting GV3P starters and LC1D40A-65A contactors side by side without intrawiring	1	GV3S

[38] To order an undervoltage trip: replace the bullet (●) with a U (for example, GVAU025).

To order a shunt trip: replace the bullet (●) with an S (for example, GVAS025).

[39] From the loss of voltage at the trip terminals to the opening of the starter contacts.

[40] One trip or one fault signaling can be fitted per GV3.

[41] Cannot be used with GV2GH7 insulator.

[42] Mounting of a GVAE contact block or a GV2AK00 visible isolation block on GV2P.

[43] Choice of N.C. or N.O. contact operation, depending on which way the reversible block is mounted.

[44] For spring terminals, add 3 to the catalog number (for example, GVAE113).

[45] The GVAD is always mounted next to the starter.

TeSys™ GV2, GV3, GV7 Manual Starters and Protectors

Table 18.136: GV7 Auxiliary Contact Blocks (auxiliary contact functions depends on location inside the device)



GV7AE11

Description	Mounting Location	Max. No. of Blocks	Contact Type	Catalog Number
Standard				
Instantaneous	Inside Device	2 per device	N.O. + N.C.	GV7AE11
Trip Indication		1 per device	N.O. + N.C.	
Fault Indication		1 per device	N.O. + N.C.	
Low Level				
Instantaneous	Inside Device	2 per device	N.O. + N.C.	GV7AB11
Trip Indication		1 per device	N.O. + N.C.	
Fault Indication		1 per device	N.O. + N.C.	

Table 18.137: GV7 Voltage Trips



GV7AD111



GV7AS055

Description	Mounting Location	Max. No. of Blocks	Voltage	Catalog Number	
Undervoltage Trip	Inside Device	1 per device	48 Vac	50 Hz	GV7AU055
			110–130 Vac	50/60 Hz	GV7AU107
			200–240 Vac	50/60 Hz	GV7AU207
			380–440/480 Vac	50/60 Hz	GV7AU387
			525 Vac	50 Hz	GV7AU525
Shunt Trip	Inside Device	1 per device	48 Vac	50 Hz	GV7AS055
			110–130 Vac	50/60 Hz	GV7AS107
			200–240 Vac	50/60 Hz	GV7AS207
			380–440/480 Vac	50/60 Hz	GV7AS387
			525 Vac	50 Hz	GV7AS525
Fault Indication	Inside Device	1 per device	24–130	–	GV7AD111
			110–415	–	GV7AD112

Table 18.138: GV7 Wiring Accessories



GV7AC01



GV7RE20

Description	Application	Catalog Number
Box Lugs	Sold in lots of 3 for GV7R•20–150[46]	GV7AC021
	Sold in lots of 3 for GV7R•220[46]	GV7AC022
Phase Barriers, Bus Bars & Shrouds		
Terminal Extension Kit	Increases center distance between phases to 45 mm	GV7AC03
Terminal Shroud Kit	Covers terminal connections for touch safe protection	GV7AC01
Phase Barriers	Provides maximum phase separation at connection points	GV7AC04
Insulating Barriers	Provides insulation between connectors and backplate	GV7AC05
Busbars and Covers	Connect to LC1F115–185 contactor	GV7AC06
	Connect to LC1F225–265 contactor	GV7AC07
Operating Handles and Accessories		
Black rotary operating handle with black legend plate (mounts directly on device)		GV7AP03
Red rotary operating handle with yellow legend plate (mounts directly on device)		GV7AP04
Conversion accessory to mount the device directly on panel door		GV7AP05
Black rotary operating handle with black legend plate and extension kit (185–600 mm)		GV7AP01
Red rotary operating handle with yellow legend plate and extension kit (185–600 mm)		GV7AP02
Padlocking device for toggle handle (max. 38 mm padlocks)		GV7V01

Table 18.139: Operating Handles



GV7AC021



GV7V01

Accessory	Description	Catalog Number
Operating Handle (Qty: 1)	NEMA 1/12 Black handle with trip indication	GVAPB54
	NEMA 1/12 Red/Yellow handle with trip indication	GVAPR54
	NEMA 3R/4/4X Black handle without trip indication	GVAPB65
	NEMA 3R/4/4X Red/Yellow handle without trip indication	GVAPR65

Dimensions: TeSys GV2 and GV3 Manual Starter and Protector Dimensions, page 18-66 and TeSys GV7 Manual Starter and Protector Dimensions, page 18-69



GV7AP03



GVAPB54



GVAPR54

[46] Wire size: GV7AC021 = 14 to 3/0 AWG; GV7AC022 = 14 AWG to 350 kcmil.

Enclosed TeSys™ D Starters

TeSys D enclosed full-voltage starters are available in Type 1 and Type 12/3R enclosures. The enclosed TeSys D offer accepts standard TeSys D accessories and all Insta-Kits™ control units and control power transformer kits. Standard capacity control power transformers with built-in fuse block can be installed in the standard enclosure. For extra capacity, please refer to your local distributor or Schneider Electric sales office.

Table 18.140: Enclosed Full Voltage Non-Reversing Starters

Max. Horsepower Ratings						Auxiliary Contacts On Each Contactor		Current Rating of Contactor	Catalog Number	Catalog Number
Single-Phase		Three-Phase				N.O.	N.C.		Type 1	Type 12/3R
115 V	230 V	200 V	230 V	460 V	575 V					
1/3	1	2	2	5	7.5	1	1	9	LE1D093A62****	LE1D093A72****
1/2	2	3	3	7.5	10	1	1	12	LE1D123A62****	LE1D123A72****
1	3	5	5	10	15	1	1	18	LE1D183A62****	LE1D183A72****
2	3	5	7.5	15	20	1	1	25	LE1D253A62****	LE1D253A72****
2	5	7.5	10	20	25	1	1	32	LE1D323A62****	LE1D323A72****
3	5	10	10	30	30	1	1	40	LE1D403A62****	LE1D403A72****
3	7.5	12	15	40	40	1	1	50	LE1D503A62****	LE1D503A72****
5	10	20	20	40	50	1	1	65	LE1D653A62****	LE1D653A72****
7.5	15	30	30	60	60	1	1	80	LE1D803A62****	LE1D803A72****

Table 18.141: Enclosed Full Voltage Reversing Starters

Max. Horsepower Ratings						Auxiliary Contacts On Each Contactor		Current Rating of Contactor	Catalog Number	Catalog Number
Single-Phase		Three-Phase				N.O.	N.C.		Type 1	Type 12/3R
115 V	230 V	200 V	230 V	460 V	575 V					
1/3	1	2	2	5	7.5	1	1	9	LE2D093A62****	LE2D093A72****
1/2	2	3	3	7.5	10	1	1	12	LE2D123A62****	LE2D123A72****
1	3	5	5	10	15	1	1	18	LE2D183A62****	LE2D183A72****
2	3	5	7.5	15	20	1	1	25	LE2D253A62****	LE2D253A72****
2	5	7.5	10	20	25	1	1	32	LE2D323A62****	LE2D323A72****
3	5	10	10	30	30	1	1	40	LE2D403A62****	LE2D403A72****
3	7.5	12	15	40	40	1	1	50	LE2D503A62****	LE2D503A72****
5	10	20	20	40	50	1	1	65	LE2D653A62****	LE2D653A72****
7.5	15	30	30	60	60	1	1	80	LE2D803A62****	LE2D803A72****

Table 18.142: Overload Relay Range (Select code from below)^[47]

Code	Range	For use on Contactors
01	0.1-0.16	D09-D32 ^[48]
02	0.16-0.25	D09-D32 ^[48]
03	0.25-0.40	D09-D32 ^[48]
04	0.40-0.63	D09-D32 ^[48]
05	0.63-1.0	D09-D32 ^[48]
06	1.0-1.6	D09-D32 ^[48]
07	1.6-2.5	D09-D32 ^[48]
08	2.5-4	D09-D32
10	4-6	D09-D32
12	5.5-8	D09-D32
13	9-13	D40, D50, D65
14	7-10	D09-D32
16	9-13	D12-D32
18	12-18	D40, D50, D65
21	12-18	D18-D32
22	16-24	D25-D32 ^[48]
	17-25	D25-D32 ^[49]
	17-25	D80
25	17-25	D40, D50, D65
30	23-28	D25-D32 ^[48]
32	23-32	D25-D32
32	23-32	D40, D50, D65
40	30-40	D40, D50, D65
50	37-50	D40, D50, D65
53	30-38	D80
55	30-40	D80
57	37-50	D80
59	48-65	D80
61	55-70	D65-D80
63	63-80	D65-D80
65	48-65	D40, D50, D65

Table 18.143: Catalog Number Nomenclature

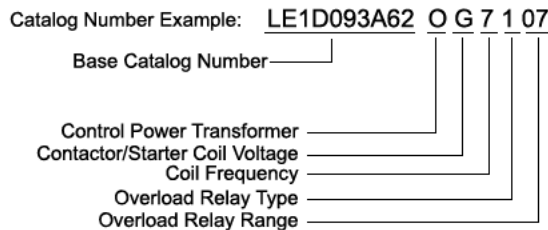

Table 18.144: Control Power Transformer
Select letter for primary voltage of CPT:

Voltage	No Transformer used	208	240	480	600
Code	O ^[50]	L	M	T	X

NOTE: If control transformer is used, the only options available are 24 or 120 V as the secondary of the transformer. Also, DC voltages are not available when control power transformer is used.

Table 18.145: Contactor/Starter Coil Voltage

Select coil voltage from table:

Voltage	24	120	208	240	480	600
AC	B	G	L	U	T	X
DC	B	—	—	—	—	—

Coil Frequency

Select:

7 = dual frequency coils (50/60 Hz)

6 = 60 Hz.

D=DC

NOTE: For 9 to 65 A contactors, only dual frequency coils are available; 80 A contactors, the 24-240 V coils are dual frequency only (50/60 Hz). The 480-600 V coils are 60 Hz. only. See catalog MKTED210011EN for other restrictions.

Overload relay type

Select:

0 = No overload relay

1 = Class 10 Trip

2 = Class 20 Trip

TeSys D dimensions: TeSys D Combination Starter Dimensions, page 18-62

[47] If no overload relay is required, leave this portion of the catalog blank.

[48] Available for Class 10 only.

[49] Available for Class 20 only.

[50] Letter O, not zero.

TeSys™ D Enclosed Fusible, Circuit Breaker and Non-Fusible

IEC combination starters combine the requirements of motor overload and short circuit protection in one convenient compact package. All devices provide Type 2 Coordination through 30 hp at 460 V. Devices are available in Type 1 and Type 12/3R enclosures. The IEC combination starter line accepts standard TeSys D accessories and all Insta-Kits™ pilot devices and control power transformer kits. Standard capacity control power transformers with built-in fuse block can be installed in the standard enclosure. For extra capacity, please refer to your local distributor or nearest Square D/Schneider Electric sales office.

NOTE: Use tables and notes from Enclosed FVRS, Overload Relays, page 18-38 to complete the catalog numbers.

Table 18.146: Enclosed Full Voltage Non-Reversing Fusible Combination Starters

Maximum Three-Phase Horsepower Ratings				Fuse Clip Rating		Auxiliary Contacts		Current Rating of Contactor	Catalog Number	
200 V	230 V	460 V	575 V	Amperes	UL Class	N.O.	N.C.		Type 1	Type 12/3R
2	2	5	7.5	30 A	CC	1	1	9	LE1D096B62.....	LE1D096B72.....
3	3	7.5	10	30 A	CC	1	1	12	LE1D126B62.....	LE1D126B72.....
5	5	10	15	30 A	J	1	1	18	LE1D186B62.....	LE1D186B72.....
5	7.5	15	20	30 A	J	1	1	25	LE1D256B62.....	LE1D256B72.....
7.5	10	20	25	60 A	J	1	1	32	LE1D326C62.....	LE1D326C72.....
10	10	30	30	60 A	J	1	1	40	LE1D406C62.....	LE1D406C72.....

Table 18.147: Enclosed Full Voltage Reversing Fusible Combination Starters

Maximum Three-Phase Horsepower Ratings				Fuse Clip Rating		Aux. Contacts Each Contactor		Current Rating of Contactor	Catalog Number	
200 V	230 V	460 V	575 V	Amperes	UL Class	N.O.	N.C.		Type 1	Type 12/3R
2	2	5	7.5	30 A	CC	1	1	9	LE2D096B62.....	LE2D096B72.....
3	3	7.5	10	30 A	CC	1	1	12	LE2D126B62.....	LE2D126B72.....
5	5	10	15	30 A	J	1	1	18	LE2D186B62.....	LE2D186B72.....
5	7.5	15	20	30 A	J	1	1	25	LE2D256B62.....	LE2D256B72.....
7.5	10	20	25	60 A	J	1	1	32	LE2D326C62.....	LE2D326C72.....
10	10	30	30	60 A	J	1	1	40	LE2D406C62.....	LE2D406C72.....

Table 18.148: Enclosed Full Voltage Non-Reversing Circuit Breaker Combination Starters

Maximum Three-Phase Horsepower Ratings				Auxiliary Contacts		Circuit Breaker Maximum Current Rating	Current Rating of Contactor	Catalog Number	
200 V	230 V	460 V	575 V	N.O.	N.C.			Type 1	Type 12/3R
2	2	5	7.5	1	1	15 A	9	LE1D097D62.....	LE1D097D72.....
3	3	7.5	10	1	1	15 A	12	LE1D127D62.....	LE1D127D72.....
5	5	10	15	1	1	30 A	18	LE1D187E62.....	LE1D187E72.....
5	7.5	15	20	1	1	30 A	25	LE1D257E62.....	LE1D257E72.....
7.5	10	20	25	1	1	50 A	32	LE1D327F62.....	LE1D327F72.....
10	10	30	30	1	1	50 A	40	LE1D407F62.....	LE1D407F72.....

Table 18.149: Enclosed Full Voltage Reversing Circuit Breaker Combination Starters

Maximum Three-Phase Horsepower Ratings				Auxiliary Contacts Each Contactor		Circuit Breaker Maximum Current Rating	Current Rating of Contactor	Catalog Number	
200 V	230 V	460 V	575 V	N.O.	N.C.			Type 1	Type 12/3R
2	2	5	7.5	1	1	15 A	9	LE2D097D62.....	LE2D097D72.....
3	3	7.5	10	1	1	15 A	12	LE2D127D62.....	LE2D127D72.....
5	5	10	15	1	1	30 A	18	LE2D187E62.....	LE2D187E72.....
5	7.5	15	20	1	1	30 A	25	LE2D257E62.....	LE2D257E72.....
7.5	10	20	25	1	1	50 A	32	LE2D327F62.....	LE2D327F72.....
10	10	30	30	1	1	50 A	40	LE2D407F62.....	LE2D407F72.....

Table 18.150: Enclosed Full Voltage Non-Reversing Non-Fused Combination Starters

Maximum Three-Phase Horsepower Ratings				Auxiliary Contacts		Current Rating of Contactor	Catalog Number	
200 V	230 V	460 V	575 V	N.O.	N.C.		Type 1	Type 12/3R
2	2	5	7.5	1	1	9	LE1D096A62.....	LE1D096A72.....
3	3	7.5	10	1	1	12	LE1D126A62.....	LE1D126A72.....
5	5	10	15	1	1	18	LE1D186A62.....	LE1D186A72.....
5	7.5	15	20	1	1	25	LE1D256A62.....	LE1D256A72.....
7.5	10	20	25	1	1	32	LE1D326A62.....	LE1D326A72.....
10	10	30	30	1	1	40	LE1D406A62.....	LE1D406A72.....

Table 18.151: Enclosed Full Voltage Reversing Non-Fused Combination Starters

Maximum Three-Phase Horsepower Ratings				Aux. Contacts Each Contactor		Current Rating of Contactor	Catalog Number	
200 V	230 V	460 V	575 V	N.O.	N.C.		Type 1	Type 12/3R
2	2	5	7.5	1	1	9	LE2D096A62.....	LE2D096A72.....
3	3	7.5	10	1	1	12	LE2D126A62.....	LE2D126A72.....
5	5	10	15	1	1	18	LE2D186A62.....	LE2D186A72.....
5	7.5	15	20	1	1	25	LE2D256A62.....	LE2D256A72.....
7.5	10	20	25	1	1	32	LE2D326A62.....	LE2D326A72.....
10	10	30	30	1	1	40	LE2D406A62.....	LE2D406A72.....

TeSys D dimensions: TeSys D Combination Starter Dimensions, page 18-62

Factory Modifications and Insta-Kits™ Selection

Add the factory modification code to the end of the catalog number created from Enclosed TeSys™ D Starters and Combination Starters, page 18-38. With the use of Insta-Kits™, only one operator scheme is allowed. Only the combinations of operators and pilot lights shown below can be ordered.

Pilot lights will be at the coil voltage indicated in the catalog number for the starter.

Table 18.152: Factory Modifications

Description	Factory Modification Code ^[51]	Insta-Kits (for field installation)
Control Units Only		
For-Rev-Stop Push Button	A06L	LA9CA06LT
Start/Stop Push Button	A06G	LA9CA06GT
/O (Start/Stop) Push Button	N/A	N/A
/O Push Button (double touch)	A06I	LA9CA06IO
Emergency Stop	N/A	N/A
Hand-Off-Auto Selector Switch	A06E	LA9CA06ET
On/Off Selector Switch	A06D	LA9CA06DT
Start/Mushroom Head Stop Push Button	A06X	LA9CA06XT
Pilot Lights only		
LED Pilot light, 24, 120 or 240 V	A16S	LA9CA16ST ^[52]
Green-Red Pilot Light, Direct Supply, 24 or 120 V ^[53]	A06S	LA9CA06ST ^[52]
Green-Red Transformer Pilot Light, 120, 208/240, 480 or 600 V ^[53]	A06F	LA9CA06FT ^[52]
Available Combination of Control Units and Pilot Lights		
Hand-Off-Auto Selector Switch w/24, 120, or 240 V LED Pilot Light	A16U	LA9CA16UT ^[52]
Start/Stop Push Button w/ 24, 120 or 240 V LED Pilot Light	A16V	LA9CA16VT ^[52]
On/Off Selector w/ 24, 120 or 240 V LED Pilot Light	A16W	LA9CA16WT ^[52]
Start/Stop Push Button w/ Green-Red Transformer Pilot Light	A06N	LA9CA06NT ^[52]
Start/Stop Push Button w/Green-Red Pilot Light	A06V	LA9CA06VT
Hand-Off-Auto Selector Switch w/Green-Red Pilot Light	A06U	LA9CA06UT
Hand-Off-Auto Selector Switch w/Green-Red Transformer Pilot Light	A06J	LA9CA06JT ^[52]
On/Off Selector w/Green-Red Pilot Light	A06W	LA9CA06WT
On/Off Selector w/Green-Red Transformer Pilot Light	A06H	LA9CA06HT ^[52]
Control Power Transformer		
Standard VA, 2 Fuses in Primary, 1 Fuse in Secondary	A206P	^[54]
50 VA extra, 2 Fuses in Primary, 1 Fuse in Secondary	A207P	^[54]
100 VA extra, 2 Fuses in Primary, 1 Fuse in Secondary	A208P	^[54]

Table 18.153: Insta-Kits™ Selection

Total VA	Insta-Kits™ Catalog Number
50	LA9TFD32 ^[52]
100	LA9TFD80 ^[52]
150	LA9TFD15 ^[52]

Table 18.154: Voltage Codes for Pilot Lights

Voltage (Vac)	24	120	208/240	480	600
Code	B	G	M	T	X

Table 18.155: Voltage Codes for Control Power Transformers

Primary Voltage	120	208	240	480	600	208	240	480	600
Secondary Voltage	24					120			
Code	E	D	C	B	A	L	M	T	X

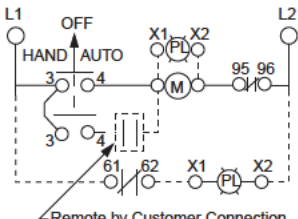
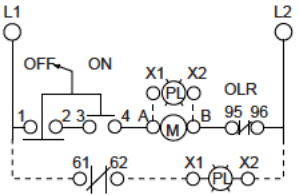
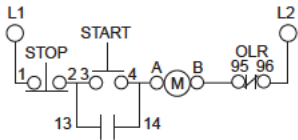

From top to bottom: Start/Stop, On-Off Selector Switch, HOA Selector Switch

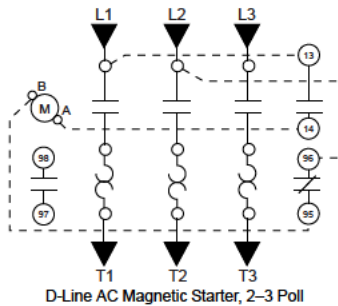

D-Line AC Magnetic Starter, 2-3 Pole

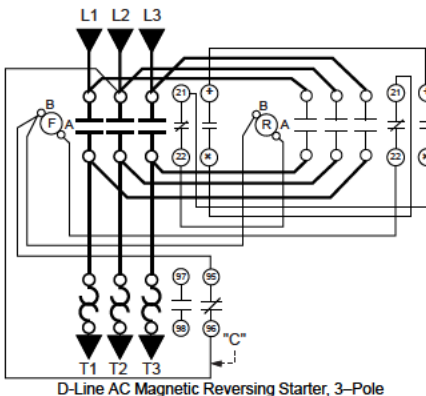

D-Line AC Magnetic Reversing Starter, 3-Pole

[51] Add these forms to the catalog number selected from Overload Relay Range, page 18-38. The numbers as shown are for use in NEMA 1 Enclosures. For uses in NEMA 12/3R change the 6 to a 7 (ex. A06U becomes A07U). Price remains the same. The change DOES NOT apply to control power transformer forms.

[52] Complete the part number for the Insta-Kits™ by selecting the voltage code from Table 18.153 Insta-Kits™ Selection, page 18-40.

[53] Pilot lights are wired such that the light is on when the contactor is energized. For non-LED type pilot lights, a green lens is installed on the unit when shipped. A red lens is included for use as applicable.

[54] Select Insta-Kits™ from Table 18.153 Insta-Kits™ Selection, page 18-40.

TeSys™ LS1 Fuse Holders

- 45 mm wide (same dimensions as GV2ME)
- Available with screw clamp and spring type terminals
- Mounts directly to LC1D09–D38 contactors (with use of GV2AF3 or GV2AF4)
- Meets application needs for fusible starter
- Uses GV2AE instantaneous contact blocks to open control circuits
- DIN rail mounted



LS1D30

Table 18.156: TeSys LS1 Fuse Holders

Description	Fuse Type	Dimensions		Use In	Catalog Number
		in.	mm		
Spring terminals, 3-pole	CC, KTK-R	0.41 x 1.5	10.3 x 38	US Markets	LS1D303
Screw clamp terminals, 3-pole	CC, KTK-R	0.41 x 1.5	10.3 x 38	US Markets	LS1D30
Spring terminals, 3-pole	aM, gG	0.39 x 1.5	10 x 38	European Markets	LS1D323
Screw clamp terminals, 3-pole	aM, gG	0.39 x 1.5	10 x 38	European Markets	LS1D32
Auxiliary main pole adder	aM, gG	0.39 x 1.5	10 x 38	European Markets	LA8D324[55]

Table 18.157: Specifications

Type	LS1D30, LS1D303	LS1D32, LS1D323, LS1DT32
Max. voltage	600 V 3 Phase	
Max. current	30 A	
Conforming to standards	IEC 60947-1, 60947-2, 60947-4-1, EN60204, BS4841, UL 508, CSA 222 2 No. 14, NFC 63-650, 63-120, 79-130, VDE 0113, 0660	
Product approvals	UL, CSA	BV
Protective treatment	"TH"	
Ambient air temperature—operation	-58 to 158° F (-50 to +70° C)	
Wiring	Number of conductors and cross sectional area (c.s. a.)	
Solid cable	2 x 16–8 AWG (1–6 mm ²)	
Flexible cable without cable end	2 x 14–8 AWG (1–6 mm ²)	
Flexible cable with cable end	2 x 16–10 AWG (1–4 mm ²)	
Resistance to mechanical impact conforming to IEC 60947-1 §7-1-6	0.5 J	
Tightening torque	15 in-lb (1.7 N·m)	
Sensitivity to phase failure	No	
Operating Positions		
Rated voltage	600 V	

Table 18.158: Environmental Specifications and Approvals

Shock resistance	30 g (conforming to EC 600 68-2-27)
Vibration resistance	5 g (5 to 150 Hz) (EC 600 68-2-26)
Ambient temperature	-40 to 176 °F (-40 to +80 °C) for storage -4 to 140 °F (-20 to +60 °C) open operation -4 to 104 °F (-20 to +40 °C) enclosed operation
Maximum operating rate	25 operations per hour
Operating current of magnetic trip	Approximately 13 times the maximum thermal trip (non-adjustable setting)



E164862
CCN NLDX

LR43364
Class 3211 04



[55] Can be mounted on left-hand or right-hand side of the 3-pole LS1D32 block.

Altistart Drive and TeSys U Motor Starter

Table 18.159: Soft Start / Soft Stop Unit for 0.75 to 15 kW Motors (can be combined with the TeSys U starter)

Motor		Starter	
Motor Power ^[1]		Nominal Current	Catalog Number
230 V HP	460 V HP		
3-phase supply voltage 200 to 480 V 50/60 Hz			
1	2	6	ATSU01N206LT
1.5	3		
2	5	9	ATSU01N209LT
3	7.5	12	ATSU01N212LT
5	10		
7.5	15	22	ATSU01N222LT
10	20	32	ATSU01N232LT

Table 18.160: Accessories

Description	Used for Starter	Catalog Number
Power connector between ATSU 01N2●●LT and TeSys U	ATSU01N2●●T	VW3G4104

Table 18.161: TeSys U Starter and Soft Start Unit Combinations

Motor Power		Soft Starter	TeSys U	
Voltage			Power Base	Control Unit ^[2]
200 V HP	460 V HP			
1	2	ATSU01N206LT	LUB 12	LUC●05BL
1.5	3	ATSU01N206LT		LUC●12BL
2	5	ATSU01N209LT		LUC●12BL
3	—	ATSU01N212LT		LUC●12BL
—	7.5	ATSU01N212LT		LUC●18BL
5	10	ATSU01N222LT		LUC●18BL
7.5	15	ATSU01N222LT	LUB 32	LUC●32BL
10	20	ATSU01N232LT		LUC●32BL



ATSU01●●

E164862
CCN NLDXLR43364
Class 3211 04

[1] Standard motor power ratings, HP power ratings indicated according to standard UL 508.

[2] Depending on the configuration of the chosen TeSys U starter, replace the ● with A for standard, B for advanced, and M for multifunction. See [Selecting TeSys U Motor Starters in Three Steps](#), page 18-23 for a complete list of available control units. Control voltage must be 24 Vdc.

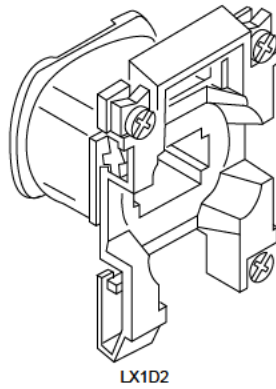

TeSys™ D AC Coils

Table 18.162: For LC1D09–D38, LC1DT20–DT40 Contactors and CAD Relays

Rated Nominal Voltage	Catalog Number 50/60 Hz
12	LXD1J7
21 ^[1]	LXD1Z7
24	LXD1B7
32	LXD1C7
36	LXD1CC7
42	LXD1D7
48	LXD1E7
60	LXD1EE7
100	LXD1K7
110	LXD1F7
115	LXD1FE7
120	LXD1G7
127	LXD1FC7
200	LXD1L7
208	LXD1LE7
220/230	LXD1M7
230	LXD1P7
230/240	LXD1U7
277	LXD1W7
380/400	LXD1Q7
400	LXD1V7
415	LXD1N7
440	LXD1R7
480	LXD1T7
575	LXD1SC7
600	LXD1X7
Specifications	50/60 Hz
Average consumption	
- Inrush (inductance 0.75)	70 VA
- Sealed (inductance 0.3)	7 VA
Operating range@ 60° C	80–110% of nominal @ 50 Hz, 85–110% of nominal @ 60 Hz

[1] Voltage for special coils fitted in contactors with serial timer modules, with 24 V supply.

TeSys™ D AC Coils

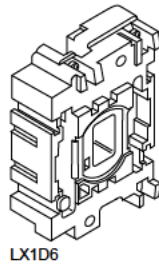

Table 18.163: For Old D2 Style LC1D40, D50, D65, D80, and D95; For TeSys D LC1D40A, D50A, D65A, DT60A, and DT80A; For TeSys D LC1D115 and D150

For Old D2 Style LC1D40, D50, D65, D80, D95				For TeSys D LC1D40A, D50A, D65A, DT60A, DT80A				For TeSys D LC1D115, D150			
Rated Nominal Voltage V	Catalog Number 50 Hz	Catalog Number 60 Hz	Catalog Number 50/60 Hz	Rated Nominal Voltage V	Catalog Number 50 Hz	Catalog Number 60 Hz	Catalog Number 50/60 Hz	Rated Nominal Voltage V	Catalog Number 50 Hz	Catalog Number 60 Hz	Catalog Number 50/60 Hz
24	LX1D6B5	LX1D6B6	LX1D6B7	12	LXD3J5	—	—	24	LX1D8B5	LX1D8B6	LX1D8B7
32	LX1D6C5	—	—	24	—	—	LXD3B7	32	LX1D8C5	—	LX1D8C7
42	LX1D6D5	—	LX1D6D7	32	—	—	LXD3C7	42	LX1D8D5	—	LX1D8D7
48	LX1D6E5	LX1D6E6	LX1D6E7	42	—	—	LXD3D7	48	LX1D8E5	LX1D8E6	LX1D8E7
110	LX1D6F5	LX1D6F6	LX1D6F7	48	—	—	LXD3E7	110	LX1D8F5	LX1D8F6	LX1D8F7
120	—	LX1D6G6	LX1D6G7	100	—	—	LXD3K7	115	LX1D8FE5	—	LX1D8FE7
127	LX1D6G5	—	—	110	—	—	LXD3F7	120	—	LX1D8G6	LX1D8G7
208	—	LX1D6L6	LX1D6L7	115	—	—	LXD3FE7	127	LX1D8FC5	—	LX1D8FC7
220	LX1D6M5	LX1D6M6	LX1D6M7	120	—	—	LXD3G7	208	—	LX1D8L6	LX1D8L7
230	LX1D6P5	—	LX1D6P7	127	—	—	LXD3FC7	220/230	LX1D8M5	LX1D8M6	LX1D8M7
240	LX1D6U5	LX1D6U6	LX1D6U7	200	—	—	LXD3L7	230	LX1D8P5	—	LX1D8P7
256	LX1D6W5	—	—	208	—	—	LXD3LE7	240	LX1D8U5	LX1D8U6	LX1D8U7
277	—	LX1D6W6	—	220	—	—	LXD3M7	277	—	LX1D8W6	LX1D8W7
380	LX1D6Q5	LX1D6Q6	LX1D6Q7	230	—	—	LXD3P7	380/400	LX1D8Q5	LX1D8Q6	LX1D8Q7
400	LX1D6V5	—	LX1D6V7	240	—	—	LXD3U7	400	LX1D8V5	—	LX1D8V7
415	LX1D6N5	—	LX1D6N7	277	—	—	LXD3W7	415	LX1D8N5	—	LX1D8N7
440	LX1D6R5	LX1D6R6	LX1D6R7	380	—	—	LXD3Q7	440	LX1D8R5	LX1D8R6	LX1D8R7
480	—	LX1D6T6	—	400	—	—	LXD3V7	480	—	LX1D8T6	LX1D8T7
500	LX1D6S5	—	—	415	—	—	LXD3N7	500	LX1D8S5	—	LX1D8S6
575	—	LX1D6S6	—	440	—	—	LXD3R7				
600	—	LX1D6X6	—	480	—	—	LXD3T7				
660	LX1D6Y5	—	—	500	—	—	LXD3S7				
				575	—	—	LXD3SC7				
				600	—	—	LXD3X7				
				660	—	—	LXD3YC7				
				690	—	—	LXD3Y7				

For old style and new TeSys style contactors where the catalog number may or may not include the auxiliary contact arrangement.

For old style and new TeSys style contactors where the catalog number may or may not include the auxiliary contact arrangement.

Specification	50 Hz	60 Hz	50/60 Hz	Specification	50 Hz	60 Hz	50/60 Hz	Specification	50 Hz	60 Hz	50/60 Hz
Average consumption: -inrush (inductance 0.75) -sealed (inductance 0.3)	200 VA 20 VA	220 VA 22 VA	245 VA 26 VA	Average consumption: -inrush (inductance 0.3) -sealed (inductance 0.3)	160 VA 7.0 VA	140 VA 7.5 VA	140 VA 7.5 VA (Inductance: 0.9) (Inductance: 0.9)	Average consumption: -inrush (inductance 0.8) -sealed (inductance 0.3)	300 VA 22 VA	300 VA 22 VA	350 VA (Inductance: 0.9) 18 VA (Inductance: 0.9)
Operating range at $\theta \leq 55^\circ\text{C} / 131^\circ\text{F}$	80–110% of nominal voltage		85–110% of nominal voltage	Operating range at $\theta \leq 55^\circ\text{C} / 131^\circ\text{F}$	85–110% of nominal voltage		80–115% of nominal voltage	Operating range at $\theta \leq 55^\circ\text{C} / 131^\circ\text{F}$	85–110% of nominal voltage		80–115% of nominal voltage

Table 18.164: TeSys™ FAC Coils (For LC1F115, F150, F185, F225, F265, F330, F400, F500, F630, F780, and F800)

Device Type	Hz	Catalog Number	Catalog Number Suffix ^[2]												
			24 V	48 V	110 V	120 V	208 V	220 V	240 V	277 V	380 V	415 V	440 V	480 V	600 V
F115–F150	50	LX1FF●	024	048	110	127	200	220	240	264	380	415	415	500	600
	60	LX1FF●	020	040	092	095	162	184	187	220	316	340	360	380	475
	40–400	LX9FF● ^[3]	—	048	110	127	200	220	220	260	380	415	415	500	—
F185, F225	50	LX1FG●	024	048	110	127	200	220	240	264	380	415	415	450	600
	60	LX1FG●	020	040	092	095	162	184	187	220	316	340	360	380	475
	40–400	LX9FG● ^[3]	—	048	110	127	200	220	220	260	380	415	415	500	—
F265–F330	40–400	LX1FH●	0242	0482	1102	1272	2002	2202	2402	2772	3802	3802	4402	5002	6002
	40–400	LX9FH● ^[3]	—	0482	1102	1272	2002	2202	2402	2772	3802	3802	...	5002	—
	40–400	LX1FJ●	—	048	110	110	200	220	240	280	380	415	415	415	600
F400	40–400	LX9FJ● ^[3]	910	917	925	925	930	931	932	932	936	936	937	937	— ^[4]
	40–400	LX1FK●	—	048	110	110	200	220	240	280	380	415	415	415	600
	40–400	LX9FK● ^[3]	910	917	925	925	930	931	932	932	936	936	937	937	— ^[4]
F500	40–400	LX1FL●	—	048	110	110	200	220	240	260	380	415	415	415	600
	40–400	LX9FL● ^[3]	910	917	924	925	930	930	931	932	935	936	936	937	— ^[4]
	40–400	LX1FL●	—	048	110	110	200	220	240	260	380	415	415	415	600
F630	40–400	LX1FL●	—	048	110	110	200	220	240	260	380	415	415	415	600
F780 ^[5]	40–400	LX1FX●	—	—	110	110	200	220	220	280	380	415	415	415	—
F800	50/60	LX4F8● ^[3]	—	—	FW	FW	—	MW	MW	—	QW	QW	QW	—	—
F1400–F2100	40–400	LX1FK● ^[3]	—	—	065	070	—	110	127	140	200	220	220	—	—

[2] Complete the catalog number by adding the suffix (for example, LX1FF024).
 [3] Also requires rectifier DR5TE4U for 110–240 V coils, DR5TE4S for 380–440 V coils.
 [4] The 600 V coils for the F400, F500 and F630 do not include an auxiliary contact for holding circuits. If required, select appropriate contacts from Blocks, page 18-15.
 [5] LC1F780 contactors operate with 2 coils as a set. The LX1FX● part number includes both coils.

Application Note on Contactor Drop-out Times

Contactors using LX1, FH, FJ, FK, FL, and FX coils have longer drop-out times. For critical applications such as emergency stop functions:

- Select a fast drop-out coil (LX9), or
- Use a maintained contact Stop button, or
- Use an interposing relay.

Table 18.165: Rectifier Table

Coil	Rectifier Catalog Number
LX9F•910	DR5TF4V
LX9F•917	
LX4F8FW	
LX4F8MW	
LX9F•925	DR5TE4U
LX9F•926	
LX9F•931	
LX9F•936	DR5TE4S
LX9F•937	
LX9F•938	
LX4F8QW	

Table 18.166: AC and DC Coil Part Numbers for LC1F1400 to F2100^[6]

Control Circuit Voltage of Contactor	Voltage Code	Spare Coil Part Number	Quantity
AC Coils			
110 V	F7	LX1FK065	2
120 V	G7	LX1FK070	2
220 V	M7	LX1FK110	2
230 V	P7	LX1FK110	2
240 V	U7	LX1FK127	2
277 V	W7	LX1FK140	2
380 V	Q7	LX1FK200	2
400 V	V7	LX1FK200	2
415 V	N7	LX1FK220	2
440 V	R7	LX1FK220	2
500 V	S7	LX1FK240	2
DC Coils			
110 V	FD	LX4FK055	2
125 V	GD	LX4FK065	2
220 V	MD	LX4FK110	2
250 V	UD	LX4FK125	2
440 V	RD	LX4FK220	2

TeSys D contactors: TeSys™ D Non-Reversing Contactors, page 18-8 and TeSys™ D Reversing Contactors, page 18-10
 TeSys F contactors: TeSys™ F Non-Reversing Contactors, page 18-12 and TeSys™ F Reversing Contactors, page 18-13
 TeSys D overload relay accessories: TeSys D Overload Relay Accessories, page 18-22
 TeSys D replacement coils: TeSys™ D AC Coils, page 18-43
 Dimensions: TeSys™ D Contactors, AC and DC Coil, page 18-51 to TeSys™ D Thermal Overload Relay Dimensions, page 18-59

^[6] These coils are standard parts included when a voltage code is added to the contactor part number LC1F1700 or LC1F2100.

TeSys™ D DC Coils

NOTE: DC coils for new TeSys D contactors LC•D09-D38, LC1DT20-DT40, LC•D40A-65A, LC1DT60A-80A, and LC•D80-D95 are not replaceable.

Table 18.167: For Old D2 LP1D80 and LC1D80^[7]

Rated Nominal Voltage V	Catalog Number	Catalog Number Wide Range ^[8]
12	LX4D7JD	LX4D7JW
24	LX4D7BD	LX4D7BW
36	LX4D7CD	LX4D7CW
48	LX4D7ED	LX4D7EW
60	LX4D7ND	—
72	LX4D7SD	LX4D7SW
110	LX4D7FD	LX4D7FW
125	LX4D7GD	—
220	LX4D7MD	LX4D7MW
250	LX4D7UD	—
440	LX4D7RD	—
600	LX4D7XD	—

Specifications		
Average consumption	22 W	23 W
Operating range at $\theta < 55^{\circ}\text{C} / 131^{\circ}\text{F}$	80–110% nominal voltage	70–120% nominal voltage

Table 18.168: For TeSys D LC1D115, 150

Rated Nominal Voltage V	Catalog Number
24	LX4D8BD
48	LX4D8ED
60	LX4D8ND
72	LX4D8SD
110	LX4D8FD
125	LX4D8GD
220	LX4D8MD
250	LX4D8UD
440	LX4D8RD

Average Consumption	Inrush 365 W, Sealed 5 W
Operating range at $\theta < 55^{\circ}\text{C} / 131^{\circ}\text{F}$	70%–120% of nominal voltage

TeSys D contactors: TeSys™ D Non-Reversing Contactors, page 18-8 and TeSys™ D Reversing Contactors, page 18-10

TeSys D overload relay accessories: TeSys D Overload Relay Accessories, page 18-22

TeSys D replacement coils: TeSys™ D AC Coils, page 18-44

TeSys D dimensions: TeSys™ D Contactors, AC and DC Coil, page 18-51 to TeSys™ D Thermal Overload Relay Dimensions, page 18-59

^[7] For old style contactors where the catalog number includes the auxiliary contact arrangement (for example, LP1D8010). The new style TeSys DC controlled contactors (for example, LC1D80BD) do not have replaceable coils.

^[8] Wide range coils cannot be used with contactors using both front- and side-mounting auxiliaries.

TeSys F DC Coils

LX4 coils are the standard coils when a voltage code is added to the part number. The LX9 coils may be ordered separately for special applications. LX9 coils do not include a built-in normally open holding circuit contact; a separate auxiliary contact block with an N.O. contact should be added to the contactor. Both the LX4 and LX9 coils can be used on previous TeSys F devices.

Table 18.169: LX4 Coils for LC1F115, F150, F185, F225, F265, F400, F500, F630, F780, F800

Device Type	Catalog Number	• Catalog Number Suffix									
		24 V	36V	48 V	60 V	72 V	110 V	125 V	220 V	250 V	440 V
F115, F150	LX4FF●	024	035	048	060	070	110	125	220	250	440
F185, F225	LX4FG●	024	035	048	060	070	110	125	220	250	440
F265, F330	LX4FH●	024	035	048	060	070	110	125	220	250	440
F400	LX4FJ●	—	—	048	060	070	110	125	220	250	440
	LX9FJ●[9]	—	—	918	—	—	926	927	932	—	938
F500	LX4FK●	—	—	048	060	070	110	125	220	250	440
	LX9FK●[9]	—	—	918	—	—	926	927	932	—	938
F630	LX4FL●	—	—	048	060	070	110	125	220	250	440
	LX9FL●[9]	—	—	918	—	—	926	927	932	—	938
F780	LX4FX●[10]	—	—	—	—	—	110	125	220	250	440
F800	LX4F8●[11]	—	—	—	—	—	FW	FW	MW	—	QW
F1400, F1700, and F2100	LX4FK●[11]	—	—	—	—	—	055	065	110	125	220

Table 18.170: LX9 Coils and Resistors

Coil	Resistor Catalog Number	Qty. Required	Coil	Resistor Catalog Number	Qty. Required	Coil	Resistor Catalog Number	Qty. Required
LX9FJ918	DR2SC0047	1	LX9FK918	DR2SC0039	1	LX9FL918	DR2SC0047	2
LX9FJ926	DR2SC0030	1	LX9FK926	DR2SC0220	1	LX9FL925	DR2SC0270	2
LX9FJ927	DR2SC0390	1	LX9FK927	DR2SC0330	1	LX9FL926	DR2SC0330	2
LX9FJ932	DR2SC1200	1	LX9FK932	DR2SC1000	1	LX9FL931	DR2SC1000	2
LX9FJ938	DR2SC4700	1	LX9FK938	DR2SC3300	1	LX9FL937	DR2SC3900	2

TeSys F contactors: TeSys™ F Non-Reversing Contactors, page 18-12 and TeSys™ F Reversing Contactors, page 18-13
 TeSys F overload relay accessories: TeSys F Overload Relay Accessories, page 18-22
 TeSys F replacement coils and parts: TeSys F Contact Kits, Arc Chambers, page 18-48, TeSys F AC Coils, page 18-44
 TeSys F dimensions: TeSys F dimensions: TeSys™ F Contactors, Dimensions, page 18-53, TeSys™ F Overload Relay Dimensions, page 18-61

[9] Coil circuit requires a separately mounted resistor. See Table 18.170 LX9 Coils and Resistors, page 18-47.
 [10] LC1F780 contactors operate on 2 coils as a set. The LX4FX part number includes both coils.
 [11] Also requires rectifier DR5TE4U.

TeSys™ F Contact Kits, Arc Chambers

Table 18.171: Replacement Contact Sets [12]

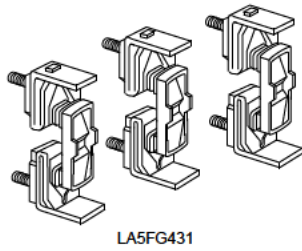

	For use on contactors	Number of Poles	Catalog Number
Two-pole	LC1F4002	2 poles	LA5F400802
	LC1F5002	2 poles	LA5F500802
	LC1F6302	2 poles	LA5F630802
Three-pole	LC1F115, F150	3 poles	LA5FF431
	LC1F185, F225	3 poles	LA5FG431
	LC1F265	3 poles	LA5FH431
	LC1F330, F400	3 poles	LA5F400803
	LC1F500	3 poles	LA5F500803
	LC1F630	3 poles	LA5F630803
	LC1F780	1 pole	LA5F780801 [13]
	LC1F800	3 poles	LA5F800803
Four-pole	LC1F1504, F1154	4 poles	LA5FF441
	LC1F1854, F2254	4 poles	LA5FG441
	LC1F2654	4 poles	LA5FH441
	LC1F3304, F4004	4 poles	LA5F400804
	LC1F5004	4 poles	LA5F500804
	LC1F6304	4 poles	LA5F630804
	LC1F7804	1 pole	LA5F780801 [13]

Table 18.172: Arc Chambers

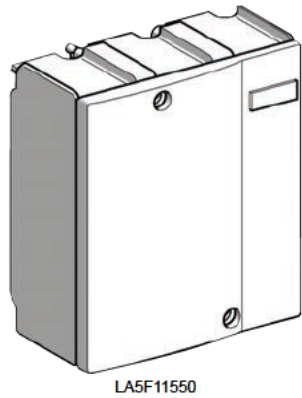

	For use on contactors	Number of Poles	Catalog Number
Two-pole	LC1F4002	2 poles	LA5F400250
	LC1F5002	2 poles	LA5F500250
	LC1F6302	2 poles	LA5F630250
Three-pole	LC1F115	3 poles	LA5F11550
	LC1F150	3 poles	LA5F15050
	LC1F185	3 poles	LA5F18550
	LC1F225	3 poles	LA5F22550
	LC1F265	3 poles	LA5F26550
	LC1F330	3 poles	LA5F33050
	LC1F400	3 poles	LA5F40050
	LC1F500	3 poles	LA5F50050
	LC1F630	3 poles	LA5F63050
	LC1F780	1 pole	LA5F780150 [13]
	LC1F800	3 poles	LA5F80050
	LC1F1400	6 poles	LA5F140050
	LC1F1700	6 poles	LA5F170050
LC1F2100	6 poles	LA5F210050	
Four-pole	LC1F1154	4 poles	LA5F115450
	LC1F1504	4 poles	LA5F150450
	LC1F1854	4 poles	LA5F185450
	LC1F2254	4 poles	LA5F225450
	LC1F2654	4 poles	LA5F265450
	LC1F3304	4 poles	LA5F330450
	LC1F4004	4 poles	LA5F400450 [14]
	LC1F5004	4 poles	LA5F500450 [14]
	LC1F6304	4 poles	LA5F630450 [15]
	LC1F7804	1 pole	LA5F780150 [13]

TeSys F contactors: TeSys™ F Non-Reversing Contactors, page 18-12 and TeSys™ F Reversing Contactors, page 18-13
 TeSys F overload relay accessories: TeSys F Overload Relay Accessories, page 18-22
 TeSys F replacement coils and parts: F AC, page 18-44, and TeSys F DC Coils, page 18-47
 TeSys F dimensions: TeSys™ F Contactors, Dimensions, page 18-53, TeSys™ F Overload Relay Dimensions, page 18-61

[12] Supplied per pole are: 2 fixed contacts, 1 moving contact, 2 deflectors, 1 backplate, mounting screws and washers.
 [13] Two identical components per pole are supplied.
 [14] Two 2-pole arc chambers.
 [15] Single-pole arc chambers.

Splitter Boxes, Power Connections and Accessories

Table 18.173: Splitter Boxes^[1]

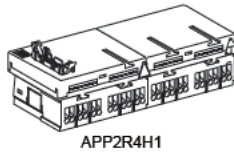

APP2R4H1

Description	Type of Control-Command Connection on Control System Side	No. of I/O per Starter	No. of Starters per Unit	Catalog Number
50 A power splitter box	—	—	2	LAD322
	—	—	4	LAD324
50 A power and control splitter box	1 x HE10 8I/8O	1I/1O	4	APP2R4H1
	1 x HE10 16I and 1 x HE10 8O	2I/1O	4	APP2R4H2
	via module APP1C●●● [2]	—	2	APP2R2E
	—	—	4	APP2R4E
	AS-Interface	2I/1O	2	APP2R2AS
—	1I/1O	4	APP2R4AS	

Table 18.174: Power Connection Components for One Starter

Description	Kit Consists Of	Catalog Number
Assembly and power connection kit	One LAD31 plate for GV2ME and two LAD34 power connection modules	LAD351
Reversing kit [3]	One set of bus bars and one mechanical interlock	LAD32

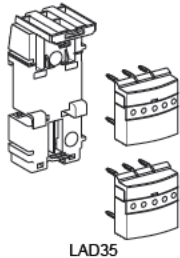

LAD35

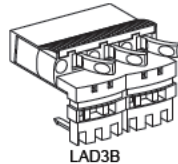

LAD3B

Table 18.175: Power Connection Accessories for One Starter

Description	Max. Connection Cross-Section	Use	Catalog Number
Upstream terminal block (50 A max)	16 mm ² (6 AWG)	Power supply for one or two power splitter boxes	LAD3B
Downstream terminal block (50 A max)	6 mm ² (10 AWG)	Connection of motor cables	LAD331

Table 18.176: Control Connection Module for One Starter

Description	D-Line Coil Voltage	Type of Coil Control Relay	Type of Starter	Catalog Number
Control connection module (integrating contact block GVAE20)	12–240 Vac or 24–125 Vdc	Electromechanical [4]	Non-reversing	APP2D1
			Reversing	APP2D2
	24–48 Vdc	Without relay [5]	Non-reversing	APP2D1D
			Reversing	APP2D2D

Table 18.177: Spare or Replacement Parts

Description	Type of Control-Command Connection on Control System Side	No. of I/O per Starter	No. of Starters	Sold in Lots of	Catalog Number
Plate for mounting a GV2ME manual starter	—	—	1	10	LAD311
Power connection module	—	—	1	10	LAD341
Control-command splitter box (single, for mounting on a power splitter box)	1 x HE10 8I/8O	1I/1O	4	1	APP2R4H3
	1 x HE10 16I and 1 x HE10 8O	2I/1O	4	1	APP2R4H4
	Per module APP1C●●● [2]	—	2	1	APP2R2C
	—	—	4	1	APP2R4C
Replacement electromechanical relay (for control connection module)	AS-Interface	2I/1O	2	1	APP2R2A
	—	1I/1O	4	1	APP2R4A
Replacement electromechanical relay (for control connection module)	—	—	1	10	APP2ER



LAD33



APP2D1●

[1] A total of up to eight starters is permissible after extensions. Use multiple quantities of the same catalog number to create the desired line-up.
 [2] Connection to an APP1C●●● module via APP2CX adapter (LAD35).
 [3] To create a TeSys D reverser, use two LC1D contactors, one assembly and power connection kit, and one reversing kit.
 [4] Relay supplied mounted on the front panel of the control connection.
 [5] The use of TeSys D low consumption contactors is recommended.

TeSys™ AK5 Panel Busbar System

The AK5 pre-fabricated bus bar system provides a quick and easy method of mounting control devices. All components are finger safe, UL Listed, CSA approved and CE marked. Although the AK5 system can be screw mounted onto any type of support, it **must be mounted** on the AM1DL201 DIN rail when component mounting plates incorporating a tap-off are used. When using tap-offs, the nominal operating current of the bus bar (160 A @ 35°) must not be exceeded. Approvals include IEC 439, UL, CSA, DNV and LROS.

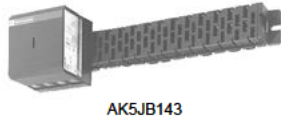

AK5JB143

Table 18.178: 160 A, 3-Phase Busbar System

Maximum number of mounting plates						Length		Catalog Number
Tap-off		Standard Width Plate		Extension Plate		in.	mm	
1.42 in.	36 mm	2.13 in.	54 mm	2.80 in.	71 mm			
6		4		2		13.39	344	AK5JB143
9		6		3		17.64	452	AK5JB144
12		8		4		21.85	560	AK5JB145
15		10		5		26.05	668	AK5JB146
24		16		8		38.69	992	AK5JB149
27		18		9		42.90	1100	AK5JB1410

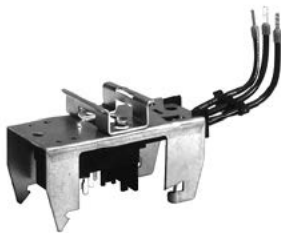

AK5PA231

Table 18.179: Mounting Plate Tap-off (plugs into busbar mounted on AM1DL201 DIN rail)

Width		Thermal Current Amperes	Application	Catalog Number
in.	mm			
2.13	54	25 A	GV2 with LUS or LUB 12 and 32 contactor reversing contactor	AK5PA231
2.13	54	25 A		AK5PA232
4.25	108	25 A		AK5PA232S

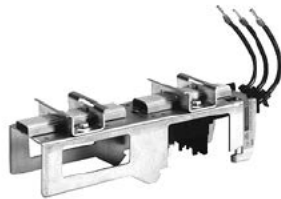

AK5PA232S

Table 18.180: Bus Tap-off (plugs into busbar for wiring to a separately mounted device)

Width		Thermal Current (A)	Length of Leads		Catalog Number
in.	mm		in.	mm	
1.42	36	32 A	9.84	250	AK5PC33
1.42	36	32 A	39.37	1000	AK5PC33L



AK5PC33



AM1DL201

Table 18.181: Extension Plates

Used to mount wider components. Bolt to standard mounting plates (after DIN rails are removed).

Width		Application	Catalog Number
in.	mm		
2.80	71	GV & Reversing contactor	AK5PE27

Table 18.182: Mounting Rail (must be used for mounting plates with tap-offs)

Description	Depth	Length	Catalog Number
	mm	mm	
75 mm Omega Rail	15	2000	AM1DL201



File E161251
CCN NMTR



File LR 89150
Class 6228-01

TeSys™ D Contactors, AC and DC Coil

Table 18.183: TeSys D 9 to 38 A Contactors, AC and DC Coils

LC1D09 to D18		LC1D25 to D38 (3-pole) and LC1DT20 to DT40 (4-pole)								
										
TeSys D contactors LC1D		D09 to D18 Inches (mm)	D093 to D123 Inches (mm)	D099 to D129 Inches (mm)	D25 to D38 Inches (mm)	D183 to D323 Inches (mm)	D098, D128, DT20, DT25 Inches (mm)	DT203, DT253 Inches (mm)	DT32, DT40 Inches (mm)	D188, D258, DT323, DT403 Inches (mm)
b	AC coil, without add-on accessories	3.03 (77)	3.89 (99)	3.14 (80)	3.36 (85)	3.89 (99)	3.34 (85)	3.89 (99)	3.58 (91)	4.13 (105)
	DC coil	3.03 (77)	3.89 (99)	3.14 (80)	3.36 (85)	3.89 (99)	3.34 (85)	3.89 (99)	3.58 (91)	4.13 (105)
b1	AC coil, with LAD4BB	3.70 (94)	4.21 (107)	3.75 (95.5)	3.85 (98)	4.21 (107)	3.85 (98)	—	—	—
	AC coil, with LA4D*2	4.33 (110) [1]	4.84 (123) [1]	4.30 (111.5) [1]	4.48 (114) [1]	4.84 (123) [1]	4.48 (114)	—	—	—
	AC coil, with LA4DF, DT	4.68 (119) [1]	5.19 (132) [1]	4.76 (120.5) [1]	4.84 (123) [1]	5.19 (132) [1]	5.02 (129)	—	—	—
c	AC coil, with LA4DR, DW, DL	4.96 (126) [1]	5.67 (139) [1]	5.0 (127.5) [1]	5.11 (130) [1]	5.47 (139) [1]	7.48 (190)	—	—	—
	AC coil, without cover or add-on blocks	3.30 (84)	3.30 (84)	3.30 (84)	3.54 (90)	3.54 (90)	3.54 (90)	3.54 (90)	3.85 (98)	3.85 (98)
	AC coil, with cover, without add-on blocks	3.38 (86)	3.38 (86)	3.38 (86)	3.62 (92)	3.62 (92)	3.62 (92)	3.62 (92)	3.93 (100)	3.93 (100)
c1	DC coil, without cover or add-on blocks	3.66 (93)	3.66 (93)	3.66 (93)	3.89 (99)	3.89 (99)	—	—	—	—
	DC coil, with cover, without add-on blocks	3.76 (95)	3.76 (95)	3.76 (95)	3.97 (101)	3.97 (101)	3.90 (99)	3.90 (99)	4.21 (107)	4.21 (107)
	AC coil, with LADN or C (two or four contacts)	4.60 (117)	4.60 (117)	4.60 (117)	4.84 (123)	4.84 (123)	4.84 (123)	4.84 (123)	5.15 (131)	5.15 (131)
c2	DC coil, with LADN or C (two or four contacts)	4.96 (126)	4.96 (126)	4.96 (126)	5.19 (132)	5.19 (132)	4.84 (123)	4.84 (123)	5.15 (131)	5.15 (131)
	AC coil, with LAD6K10	5.07 (129)	5.07 (129)	5.07 (129)	5.31 (135)	5.31 (135)	5.31 (135)	5.31 (135)	5.62 (143)	5.62 (143)
c3	DC coil, with LAD6K10	5.43 (138)	5.43 (138)	5.43 (138)	5.66 (144)	5.66 (144)	5.31 (135)	5.31 (135)	5.62 (143)	5.62 (143)
	AC coil, with LADT, R, S	5.39 (137)	5.39 (137)	5.39 (137)	5.62 (143)	5.62 (143)	5.62 (143)	5.62 (143)	5.94 (151)	5.94 (151)
	AC coil, with LADT, R, S and sealing cover	5.55 (141)	5.55 (141)	5.55 (141)	5.78 (147)	5.78 (147)	5.78 (147)	5.78 (147)	6.10 (155)	6.10 (155)
	DC coil with LADT, R, S	5.76 (146)	5.76 (146)	5.76 (146)	5.98 (152)	5.98 (152)	5.62 (143)	5.62 (143)	5.94 (151)	5.94 (151)
	DC coil with LADT, R, S and sealing cover	5.90 (150)	5.76 (146)	5.76 (146)	6.14 (156)	6.14 (156)	5.78 (147)	5.78 (147)	6.10 (155)	6.10 (155)

Table 18.184: TeSys D 40 A to 65 A, AC and DC coil

LC1 D40A–D65A (3P), LC1 DT60A–DT80A (4P) AC OR DC		LC1		D40A–D65A in. (mm)	DT60A–DT80A in. (mm)
	a	with LA4 D*2	—	2.17 (55)	2.76 (70)
	b1	with LA4 DB3 or LAD 4BB3	5.35 (136)	—	—
c		with LA4 DF, DT	6.18 (157)	—	—
	c1	with LA4 DM, DW, DL	6.54 (166)	—	—
c2		without cover or add-on blocks	4.65 (118)	4.65 (118)	—
	c3	with cover, without add-on blocks	4.72 (120)	4.72 (120)	—
c1		with LADN (1 contact)	—	—	—
	c2	with LADN or C (2 or 4 contacts)	5.91 (150)	5.91 (150)	—
c3		with LAD 6K10 or LA6 DK	6.42 (163)	6.42 (163)	—
	c3	with LADT, R, S	6.73 (171)	6.73 (171)	—
c3		with LADT, R, S and sealing cover	6.89 (175)	6.89 (175)	—

Table 18.185: TeSys D80 and D95 AC Coil

LC1D80 and D95 (3P), LP1 D80004 and D80008 (4P)		LC1		D80 in. (mm)	D95 in. (mm)	D80004 in. (mm)	D80008 in. (mm)
	a	with LA4 D*2	3.35 (85)	3.35 (85)	3.78 (96)	3.78 (96)	
	b1	with LA4 DB3 or LAD 4BB3	5.31 (135)	5.31 (135)	5.31 (135)	5.31 (135)	
c		with LA4 DF, DT	5.59 (142)	5.59 (142)	5.59 (142)	5.59 (142)	
	c1	with LA4 DM, DW, DL	5.90 (150)	5.90 (150)	5.90 (150)	5.90 (150)	
c2		without cover or add-on blocks	4.92 (125)	4.92 (125)	4.92 (125)	5.51 (140)	
	c3	with cover, without add-on blocks	5.12 (130)	5.12 (130)	—	—	
c1		with LADN (1 contact)	5.90 (150)	5.90 (150)	5.90 (150)	5.90 (150)	
	c2	with LADN or C (2 or 4 contacts)	6.22 (158)	6.22 (158)	6.22 (158)	6.22 (158)	
c3		with LAD 6K10 or LA6 DK	6.69 (170)	6.69 (170)	6.69 (170)	6.69 (170)	
	c3	with LADT, R, S	7 (178)	7 (178)	7 (178)	7 (178)	
c3		with LADT, R, S and sealing cover	7.16 (182)	7.16 (182)	7.16 (182)	7.16 (182)	

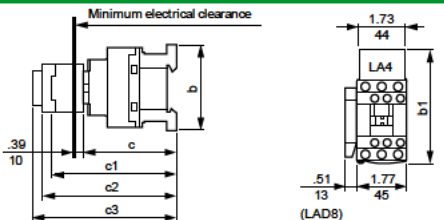
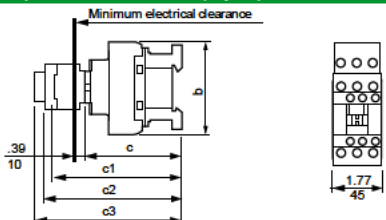
[1] Including LAD4BB

TeSys™ D Contactors, DC Coil

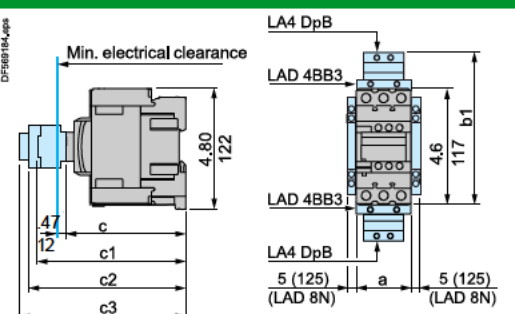
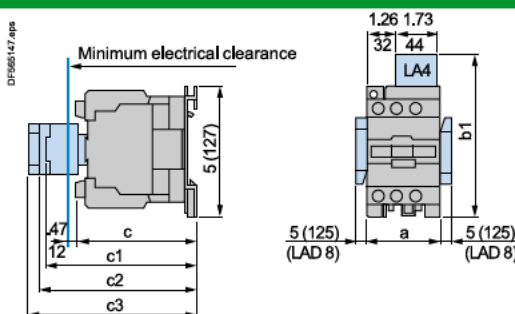
Table 18.186: DC Coil

LC1D80, D95 (3P), LP1D80004, D80008 (4P)		LC1	D80 and D95	D80004	D80008
			in. (mm)	in. (mm)	in. (mm)
<p>Minimum electrical clearance</p> <p>1.26 1.73 32 44 LA4</p> <p>5 (125) (LAD 8)</p> <p>5 (125) (LAD 8)</p> <p>47 12 c c1 c2 c3</p> <p>5 (127)</p>	a	with LAD 4BB3	3.35 (85)	3.78 (96)	3.78 (96)
	b1	with LA4 DF, DT	—	—	—
		without cover or add-on blocks	7.13 (181)	7.13 (181)	7.72 (196)
	c	with cover, without add-on blocks	7.32 (186)	—	—
		with LAD N (1 contact)	8.03 (204)	8.03 (204)	8.03 (204)
	c1	with LAD N or C (2 or 4 contacts)	8.27 (210)	8.27 (210)	8.27 (210)
	c2	with LA6 DK10	8.70 (221)	8.70 (221)	8.70 (221)
	c3	with LAD T, R, S	9.01 (229)	9.01 (229)	9.01 (229)
		with LAD T, R, S and sealing cover	9.17 (233)	9.17 (233)	9.17 (233)

LC1D115, D150 (3P), LC1D115004 (4P), AC and DC Coils Panel mounted with 1/4" screws		LC1	D115, D150	D115004	D1150046
			in. (mm)	in. (mm)	in. (mm)
<p>Min. electrical clearance</p> <p>39 10 6.22 158</p> <p>LA4</p> <p>LAD 8</p> <p>b1</p> <p>a</p> <p>c c1 c2 c3</p> <p>With 2 or 4 contacts. + 4 mm with sealing cover.</p>	a	with LA4DA2	(120)	(150)	(155)
	b1	with LA4DF, DT	(174)	(174)	(174)
		with LA4DM, DL	(188)	(188)	(188)
		with LA4DW	(132)	(132)	(115)
		without cover or add-on blocks	(136)	—	—
	c	with cover, without add-on blocks	(136)	—	—
	c1	with LAD N or C (2 or 4 contacts)	(150)	(150)	(150)
	c2	with LA6DK20	(155)	(155)	(155)
	c3	with LAD T, R, S	(168)	(168)	(168)
		with LAD T, R, S and sealing cover	(172)	(172)	(172)

TeSys™ F Contactors, Dimensions

All dimensions shown in mm.
To convert to inches, divide by 25.4.

LC1F115 to F330

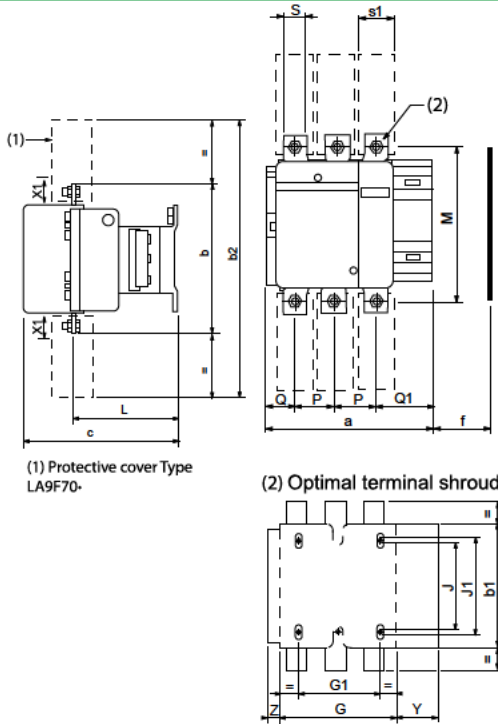

Table 18.187: LC1F115–F330 Dimensions

LC1	F115		F150		F185		F225		F265		F330	
	3-Pole	4-Pole	3-Pole	4-Pole	3-Pole	4-Pole	3-Pole	4-Pole	3-Pole	4-Pole	3-Pole	4-Pole
a	163.5	200.5	163.5	200.5	168.5	208.5	168.5	208.5	201.5	243.5	213	261
b	162	162	170	170	174	174	197	197	203	203	206	206
b1	137	137	137	137	137	137	137	137	145	145	145	145
b2	265	265	301	301	305	305	364	364	370	370	375	375
c	165 [2]	165 [2]	165 [2]	165 [2]	176	176	181	181	207	207	219	219
f	131	131	131	131	130	130	130	130	147	147	147	147
G	106	143	106	143	111	151	111	151	142	190	154.5	202.5
G1	80	80	80	80	80	80	80	80	96	96	96	96
J	106	106	106	106	106	106	106	106	106	106	106	106
J1	120	120	120	120	120	120	120	120	120	120	120	120
L	107	107	107	107	113.5	113.5	113.5	113.5	141	141	145	145
M	147	147	150	150	154	154	172	172	178	178	181	181
P	37	37	40	40	40	40	48	48	48	48	48	48
Q	29.5	29.5	26.5	26	29	29	21	17	39	34	43	43
Q1	60	60	57.5	55.5	59.5	59.5	51.5	47.5	66.5	66.5	74	74
S	15	15	20	20	20	20	25	25	25	25	25	25
S1	27	27	34	34	34	34	44.5	44.5	38	38	44.5	44.5
Y	44	44	44	44	44	44	44	44	38	38	38	38
Z	13.5	13.5	13.5	13.5	13.5	13.5	13.5	13.5	21.5	21.5	20.5	20.5

f = minimum distance required for coil removal.

Table 18.188: LC1F115–F330 Voltage

	200 to 500 V	600 to 1000 V
LC1F115, F150	10	15
LC1F185	10	15
LC1F225, F265	10	15
LC1F330	10	15

X1: Minimum clearance according to the operational voltage and the breaking capacity.

LC1F400 to F500

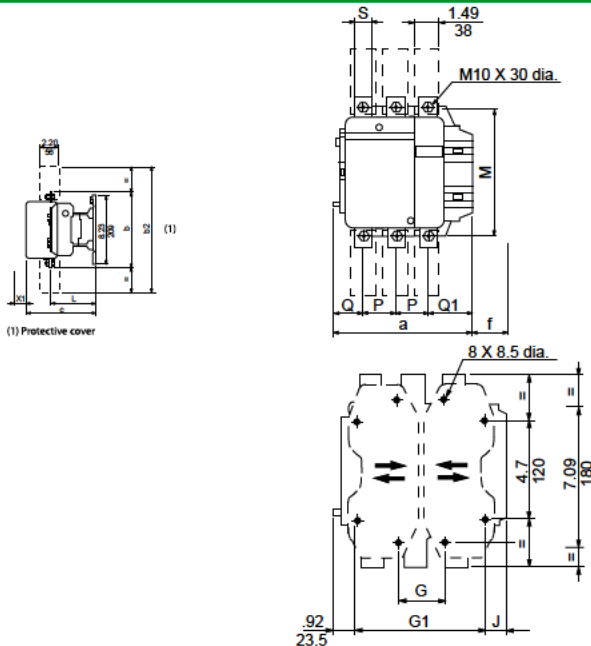

Table 18.189: LC1F400–F500 Dimensions

LC1	F400			F500		
	2-Pole	3-Pole	4-Pole	2-Pole	3-Pole	4-Pole
a	213	213	261	233	233	288
b	206	206	206	238	238	238
b2	375	375	375	400	400	400
c	213	213	213	226	226	226
f	119	119	119	141	141	141
G	80	80	80	80	80	140
G min.	66	66	66	66	66	66
G max.	102	102	150	120	120	175
G1 [3]	170	170	170	170	170	230
G1 min.	156	156	156	156	156	156
G1 max.	192	192	240	210	210	265
J	19.5	19.5	67.5	39.5	39.5	34.5
L	145	145	145	146	146	146
M	181	181	181	208	208	208
P	48	48	48	55	55	55
Q	69	43	43	76	46	46
Q1	96	74	74	102	77	77
S	25	25	25	30	30	30

f = Minimum distance required for coil removal.

Table 18.190: LC1F400–F500 Voltage

	200 to 500 V	600 to 1000 V
LC1F400	15	20
LC1F500	15	20

X1: Minimum clearance according to the operational voltage and the breaking capacity.

[2] +6 mm with time delay block (for F115 and F150).
[3] Supplied

Table 18.191: LC1F Dimensions

LC1F630 and LC1F800

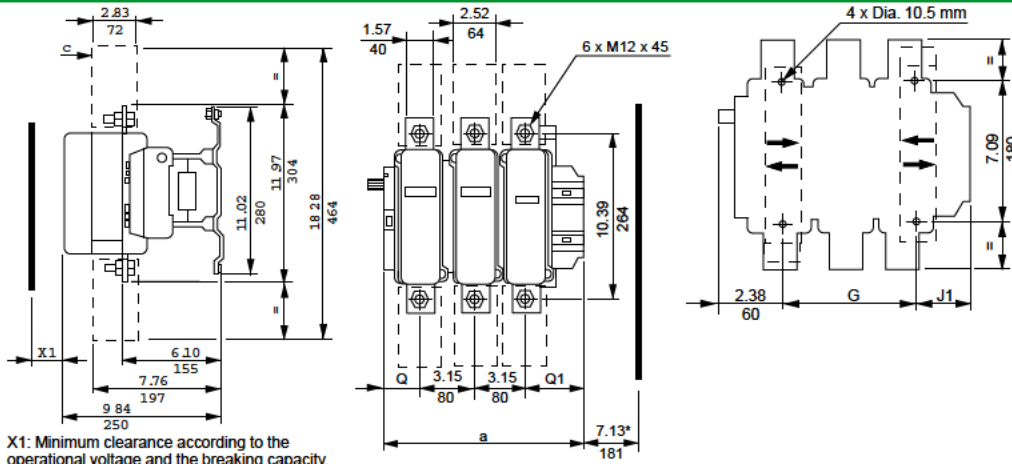

X1: Minimum clearance according to the operational voltage and the breaking capacity.

	LC1F630	a	G supplied	G min.	G max.	J1	Q	Q1							
* = minimum distance required for coil removal.	2 P	12.17	309	7.09	180	3.94	100	7.68	195	2.70	68.5	4.02	102	5.00	127
♦ Protective terminal cover.	3 P	12.17	309	7.09	180	3.94	100	7.68	195	2.70	68.5	2.36	60	3.50	89
	4 P	15.31	389	9.45	240	5.91	150	10.83	275	2.70	68.5	2.36	60	3.50	89

Voltage (V)	200 to 500 V	690 to 1000 V	200 to 690 V	1000 V
F630	20	30	—	—
F800	—	—	10	20

18 CONTACTORS AND STARTERS-IEC

LC1F780, F7804

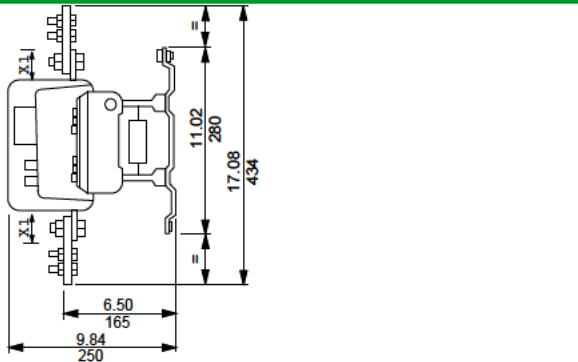

X1: Minimum clearance according to the operational voltage and the breaking capacity.

Voltage (V)	200 to 500 V	690 to 1000 V
X1 in mm	30	35

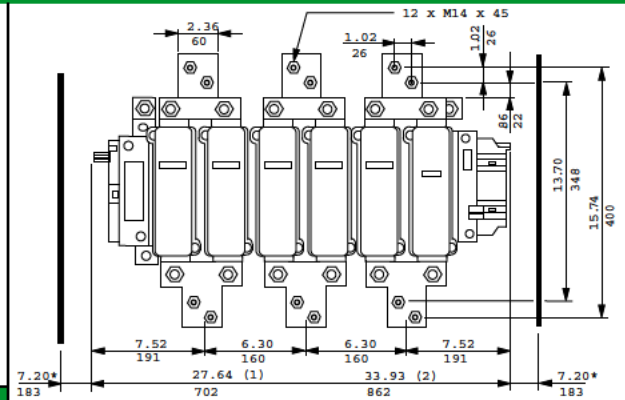

1) Overall length (3 poles).
2) Overall length (4 poles).
* Minimum distance required for coil removal.

LC1F780 mounting

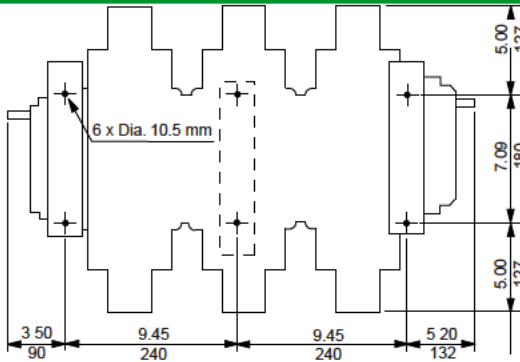

LC1F7804 mounting

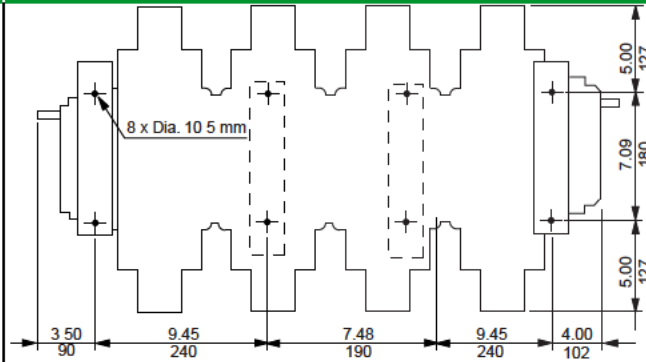

TeSys™ D Reversing Contactor Dimensions

Table 18.192: Reversing Contactor Dimensions

LC2D09–D38 2 x LC1D09 to D38 LC2DT20 to DT40 2 x LC1 DT20 to DT40

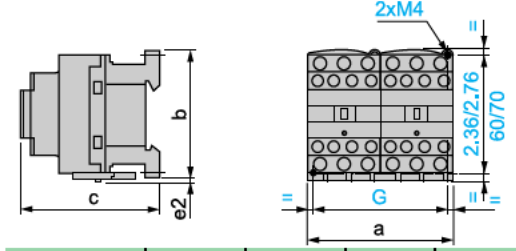
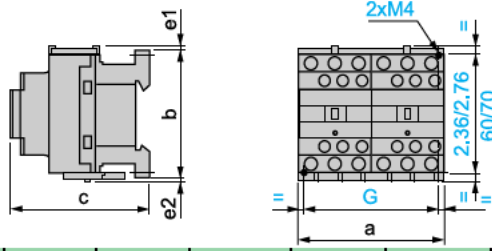

LC2 or 2 x LC1	a	b	c ^[4]	e1	e2	G
	in. (mm)	in. (mm)	in. (mm)	in. (mm)	in. (mm)	in. (mm)
D09 to D18 (AC Coil)	3.54 (90)	3.03 (77)	3.38 (86)	0.16 (4)	0.06 (1.5)	3.14 (80)
D093 to D123 (AC Coil)	3.54 (90)	3.9 (99)	3.38 (86)	—	—	3.14 (80)
D09 to D18 (DC Coil)	3.54 (90)	3.03 (77)	3.74 (95)	0.16 (4)	0.06 (1.5)	3.14 (80)
D093 to D123 (DC Coil)	3.54 (90)	3.9 (99)	3.74 (95)	—	—	3.14 (80)
D25 to D38 (AC Coil)	3.54 (90)	3.34 (85)	3.62 (92)	0.35 (9)	0.20 (5)	3.14 (80)
D183 to D383 (AC Coil)	3.54 (90)	3.9 (99)	3.62 (92)	—	—	3.14 (80)
D25 and D32 (DC Coil)	3.54 (90)	3.34 (85)	3.98 (101)	0.35 (9)	0.20 (5)	3.14 (80)
D183 to D383 (DC Coil)	3.54 (90)	3.9 (99)	3.98 (101)	—	—	3.14 (80)

LC2 or 2 x LC1	a	b	c	G
	in. (mm)	in. (mm)	in. (mm)	in. (mm)
DT20 and DT25 (AC Coil)	3.54 (90)	3.34 (85)	3.62 (92)	3.14 (80)
DT32 and DT40 (AC Coil)	3.54 (90)	3.58 (91)	3.9 (99)	3.14 (80)
DT20 and DT25 (DC Coil)	3.54 (90)	3.34 (85)	4 (102)	3.14 (80)
DT32 and DT40 (DC Coil)	3.54 (90)	3.58 (91)	4.29 (109)	3.14 (80)

c, e: includes cabling

e1 and e2: includes cabling

LC2D40A to D65A 2 x LC1D40A to D65A

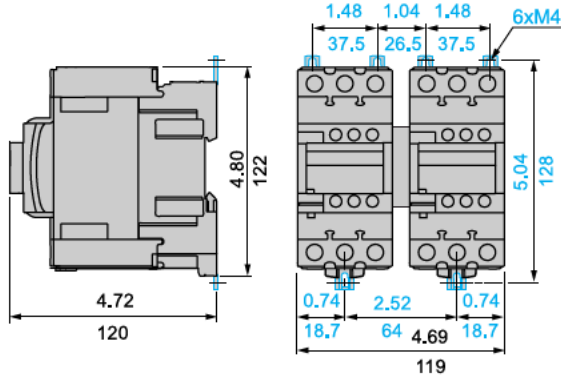

LC2D80 and D95 2 x LC1D80 and D95 (AC Coil) 2 x LC1D80 and D95 (DC Coil)

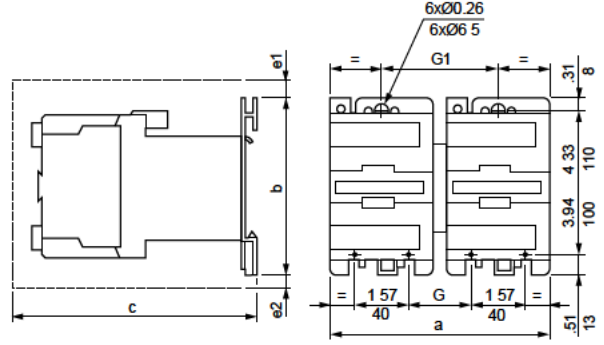
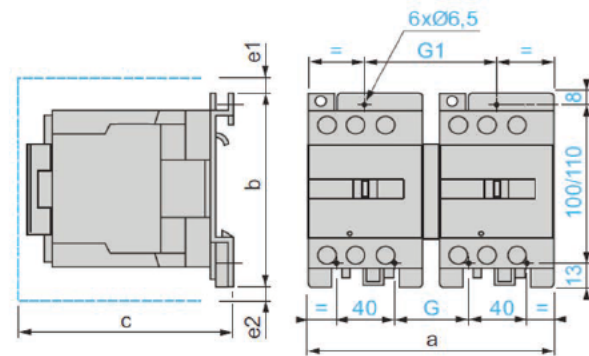

LC2 or 2 x LC1	a	b	c	e1	e2	G	G1
	in. (mm)	in. (mm)	in. (mm)	in. (mm)	in. (mm)	in. (mm)	in. (mm)
D80 and D95	7.17 (182)	5 (127)	6.22 (158)	0.51 (13)	—	2.24 (57)	3.78 (96)
D80004	8.15 (207)	5 (127)	6.22 (158)	—	0.79 (20)	2.8 (71)	4.37 (111)

2 x LC1	a	b	c	e1	e2	G	G1
	in. (mm)	in. (mm)	in. (mm)	in. (mm)	in. (mm)	in. (mm)	in. (mm)
D80 and D95	8.15 (207)	5.0 (127)	8.46 (215)	0.51 (13)	0.79 (20)	3.78 (96)	4.37 (111)

c, e1 and e2: includes cabling.

c, e1, and e2: includes cabling

[4] With safety cover, without add-on block.

LC2D115 and D150
2 x LC1D115 and D150

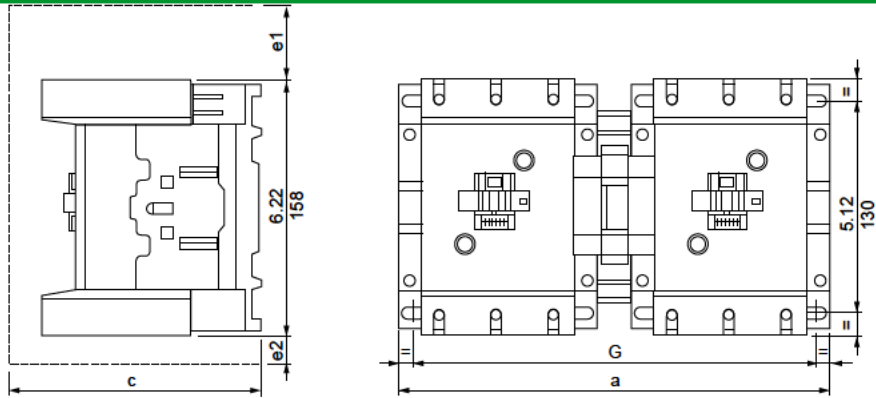

LC2 or 2 x LC1	a	c	e1	e2	G
	in. (mm)	in. (mm)	in. (mm)	in. (mm)	in. (mm)
D115, D150	10.47 (266)	5.83 (148)	2.2 (56)	0.71 (18)	9.53/10.08 (242/256)
D115004	13.15 (334)	5.83 (148)	—	2.36 (60)	12.2/12.76 (310/324)

c, e1 and e2 includes cabling

NOTE: For dimensions of TeSys F reversing contactors, please refer to catalog MKTED210011EN.

TeSys™ D Open Starter Dimensions

Table 18.193: TeSys D Thermal Overload Relay Dimensions, in. (mm)

LRD01-35
Direct mounting beneath contactors with screw clamp connections

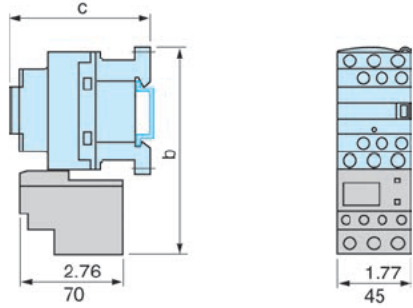

LC1•	D09–D18	D25–D38
b	4.84 (123)	5.39 (137)
c	See TeSys™ D Contactors, AC and DC Coil, page 18-51	

LRD04L-32L
Direct mounting beneath contactors with screw clamp connections

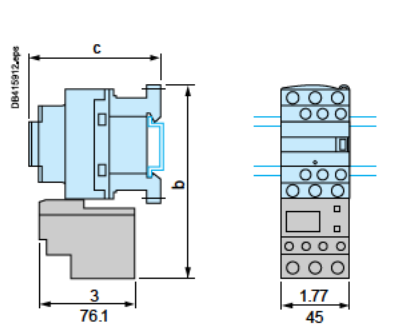

LC1•	D09–D18	D25–D38
b	4.84 (123)	5.39 (137)
c	See TeSys™ D Contactors, AC and DC Coil, page 18-51	

LRD013-223
Direct mounting beneath contactors with spring terminal connections

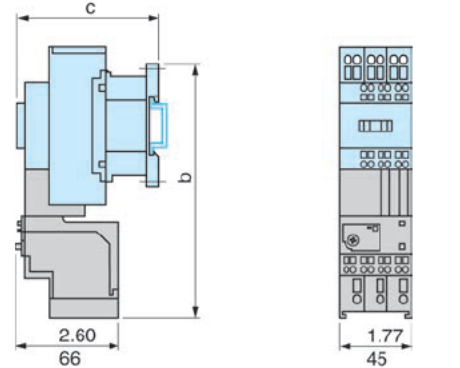

LC1•	D093–383
b	6.61 (168)
c	See TeSys™ D Contactors, AC and DC Coil, page 18-51

LR9D01, 02, 08, and 32

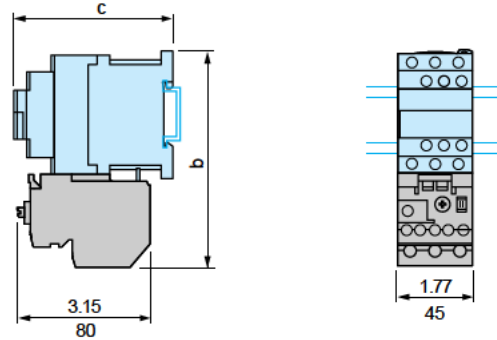

LC1•	D09–D18	D25–D38
b	5.12 (130)	5.51 (140)
c	See TeSys™ D Contactors, AC and DC Coil, page 18-51	See TeSys™ D Contactors, AC and DC Coil, page 18-51

LRD313–365
Direct mounting beneath LC1D40A to D65A with screw clamp connectors or EverLink connectors

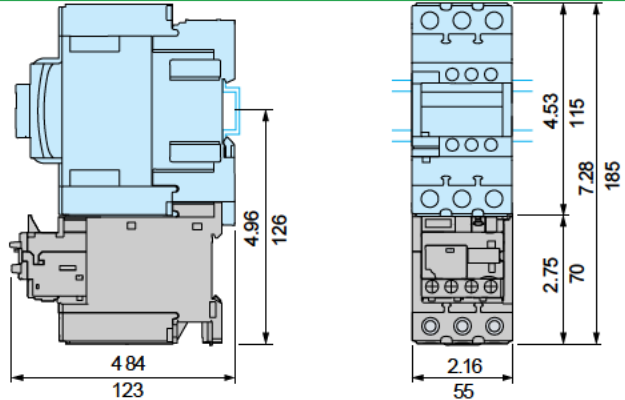

LRD3136–3656
Direct mounting beneath contactors LC1D40A6 to D65A6 with lugs

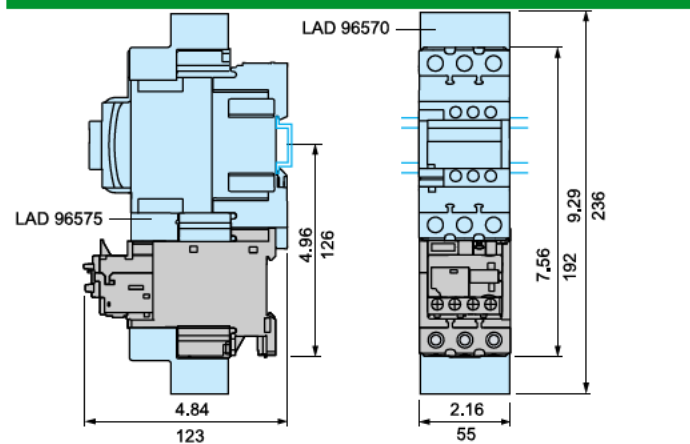

LRD33...
Direct mounting beneath contactors
LC1D80 to D95

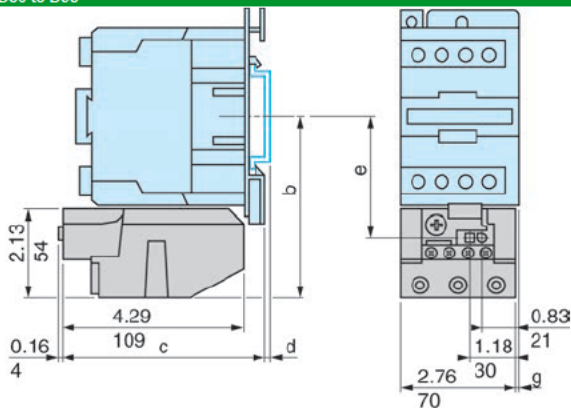

AM1 d	DL201 0.28 (7)			DL200 0.67 (17)	
	b	c	e	g (3P)	g (4P)
AC Control Circuit					
LC1D80	4.55 (115.5)	4.88 (124)	3 03 (76.9)	0.37 (9.5)	0.87 (22)
LC1D95	4.55 (115.5)	4.88 (124)	3 03 (76.9)	0.37 (9.5)	—
DC Control Circuit					
LP1D80	4.55 (115.5)	7.06 (179.4)	3 03 (76.9)	0.37 (9.5)	0.87 (22)

LRD4...[5]
Direct mounting beneath contactors LC1D115 and D150

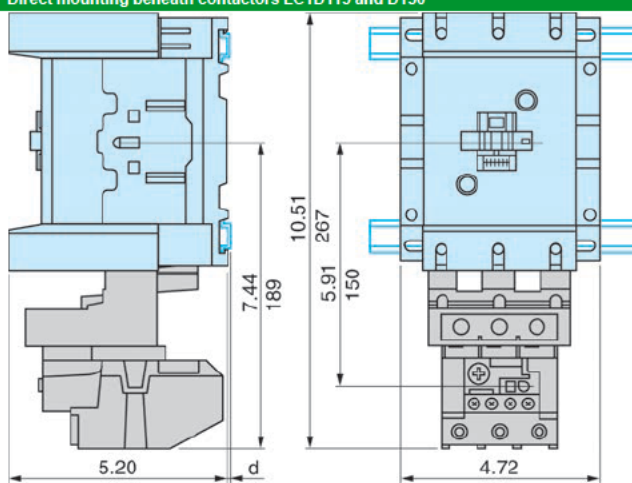

AM1 d	DL200 and DR200 0.10 (2.5)	DE200 and ED... 0.41 (10.5)
----------	-------------------------------	--------------------------------

LR9D5... and LR9D6...[5]
Direct mounting beneath contactors LC1D115 and D150

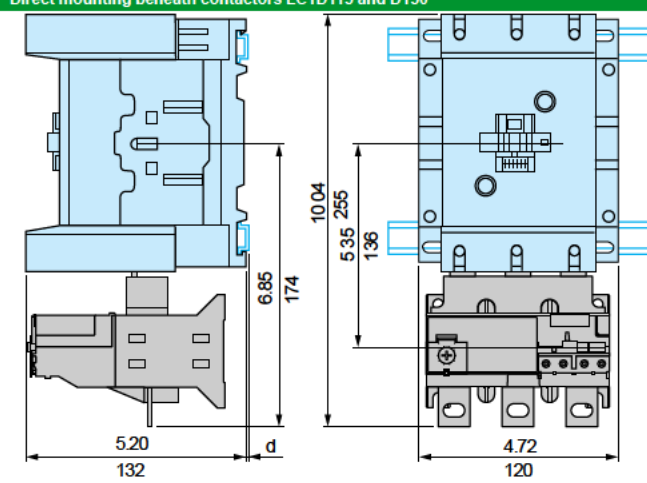

AM1 d	DP200 and DR200 0.10 (2.5)	DE200 and ED... 0.41 (10.5)
----------	-------------------------------	--------------------------------

[5] For additional specifications and selection information, see catalog MKTED210011EN

TeSys™ D Thermal Overload Relay Dimensions

LRD01–35 Independent mounting on 1.97 in. (50 mm) centers or on rail AM1DP200 or DE200 Independent mounting on 4.33 in. (110 mm) centers

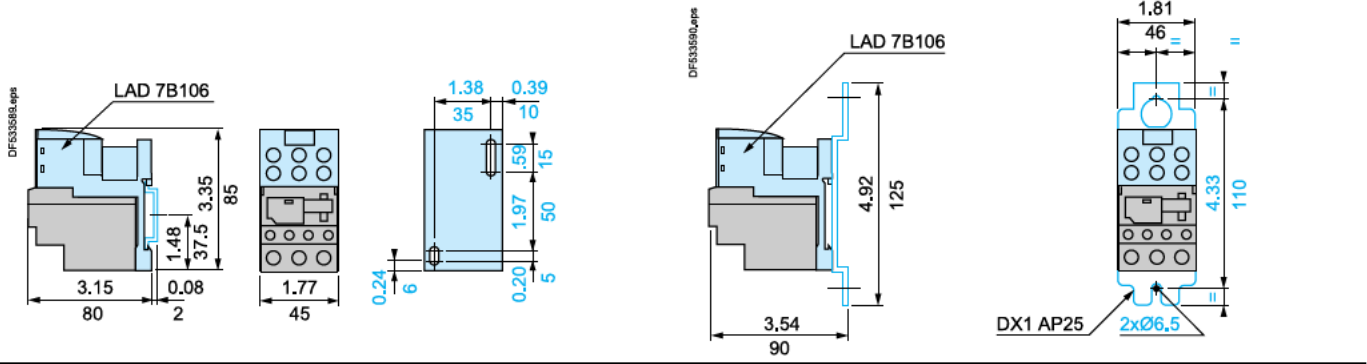

LRD04L–32L Independent mounting on 1.97 in. (50 mm) centers or on rail AM1DP200 or DE200 Independent mounting on 4.33 in. (110 mm) centers

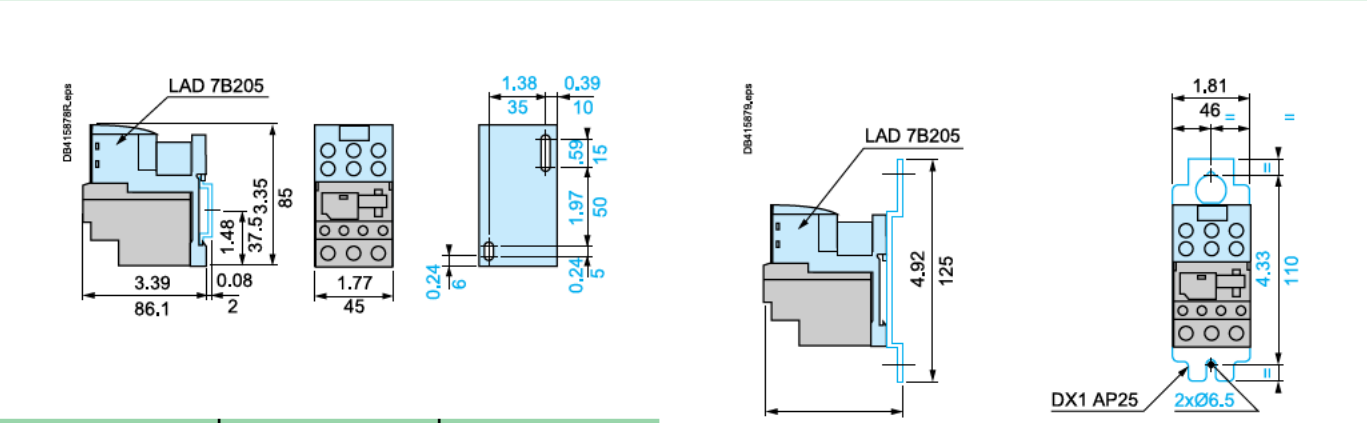

	AM1	DP200	DE200
d		0.08 (2)	0.37 (9.5)

LRD313–365 Mounting on rail AM1DP200 or ED200 Panel mounting Mounted on plate AM1P

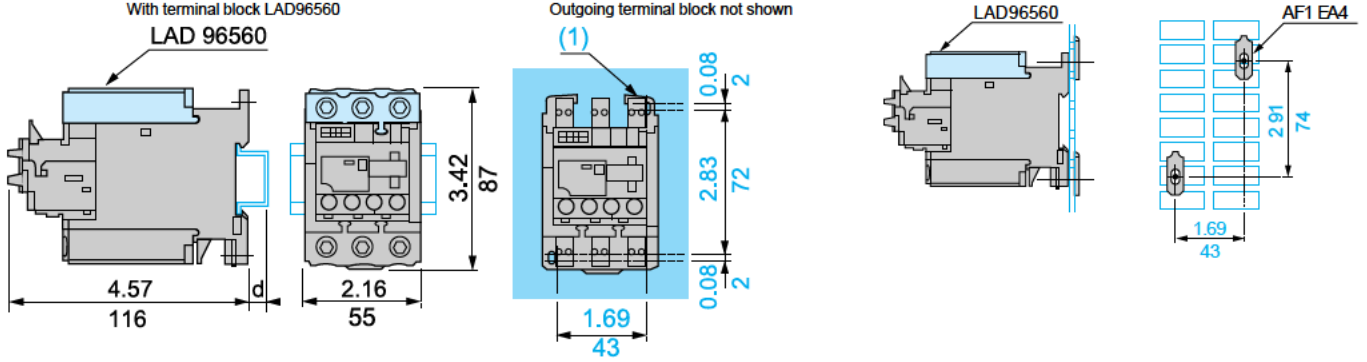

	AM1	DP200	DE200	ED200
d		0.08 (2)	0.37 (9.5)	0.37 (9.5)

LRD01–35 and LRD313–365 Remote tripping or electrical reset

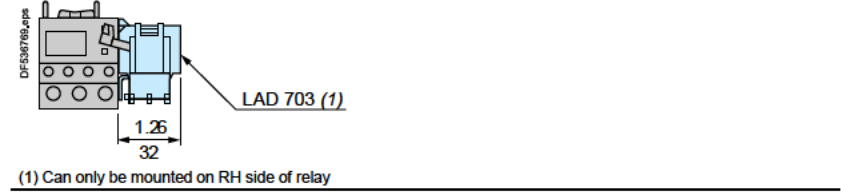

(1) Can only be mounted on RH side of relay

LR9D01-D32

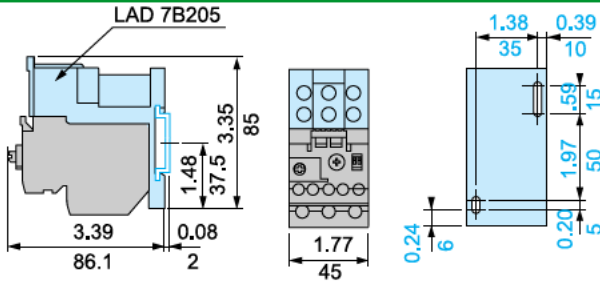

LR9D110S

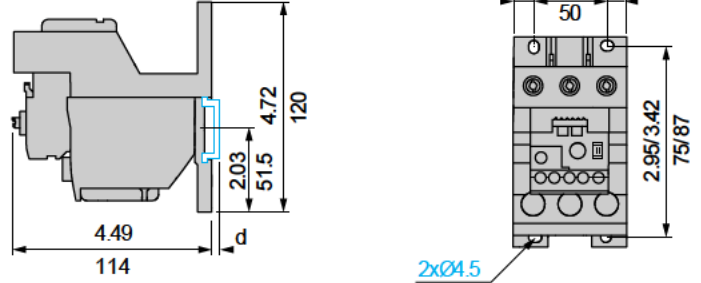

LRD3... and LR2D35...
Independent mounting on 1.97 in. (50 mm) centers or on rail AM1DP200 or DE200

LRD3..., LR2D35..., and LR9D5
Remote tripping or electrical reset

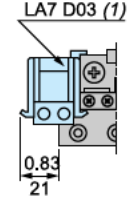
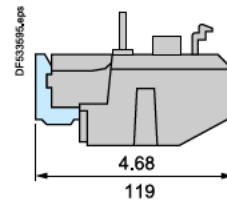
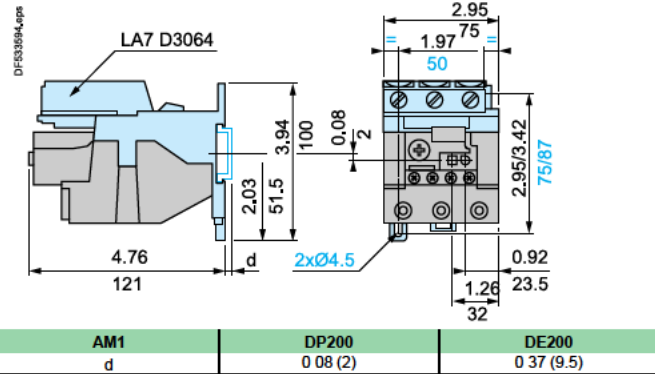

(1) Can be mounted on RH or LH side of relay LRD3..., LR2D35..., or LR9D

	AM1	DP200	DE200
d		0 08 (2)	0 37 (9.5)

LRD3...
Adapter for door-mounted operator

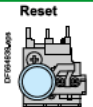
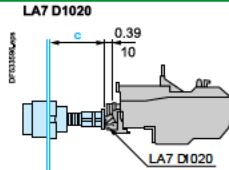

c: adjustable from 0.67 to 4.72 (17 to 120)

LRD, LRD313-365, LRD04-32L, LR9D5, and LR9D6
"Reset" by flexible cable

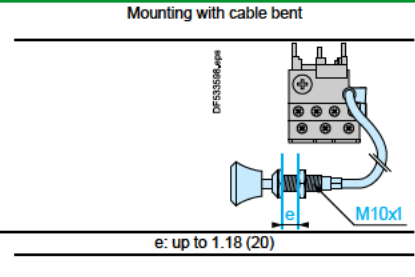
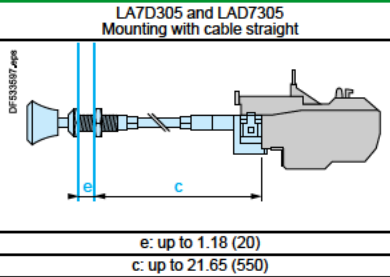

TeSys™ F Overload Relay Dimensions

All dimensions shown in mm.
To convert to inches, divide by 25.4.

Table 18.194: TeSys F Overload Relay Dimensions

LR9F5•71, F71	LR9F5•57, F5•63, F5•67, F5•69, F57, F63, F67, F69
Common side view	Common side view
1) Terminal shroud LA9F70•	2) 6.5 x 13.5 for LR9F5•57 and F57. 8.5 x 13.5 for LR9F5•63, F5•67, F5•69, F63, F67, F69.

LR9F7•75, F7•79, F7•81, F75, F79, F81	LR9F7•81, F81									
Common side view	Common side view									
(1) Terminal shroud LA9-F70•	(for mounting beneath LC1F630 and LC1F800)									
<table border="1"> <thead> <tr> <th></th> <th>P1</th> <th>P2</th> </tr> </thead> <tbody> <tr> <td>LR9F7•75, F75</td> <td>48</td> <td>48</td> </tr> <tr> <td>LR9F7•79, F7•81, F79, F81</td> <td>55</td> <td>55</td> </tr> </tbody> </table>		P1	P2	LR9F7•75, F75	48	48	LR9F7•79, F7•81, F79, F81	55	55	
	P1	P2								
LR9F7•75, F75	48	48								
LR9F7•79, F7•81, F79, F81	55	55								

Direct mounting beneath contactor LC1F	Direct mounting beneath reversing contactors or star-delta contactors
(2) Relay mounting plate, see Mounting Plate for Overload Relay, page 18-22.	(1) Connection accessories, see Connection Accessories, page 18-22. (2) Relay mounting plate, see Mounting Plate for Overload Relay, page 18-22.

LC1 contactors	With LR9 relays	b	H1	H2	H3	LC1 contactors	With LR9 relays	b	H4	H2	H3
F115	F5•57, F5•63, F5•67, F5•69, F57, F63, F67, F69	240	30	76	120	F115	F5•57, F5•63, F5•67, F5•69, F57, F63, F67, F69	279	60	76	120
F150	F5•57, F5•63, F5•67, F5•69, F57, F63, F67, F69	246	30	76	120	F150	F5•57, F5•63, F5•67, F5•69, F57, F63, F67, F69	283	60	76	120
F185	F5•57, F5•63, F5•67, F5•69, F57, F63, F67, F69	250	30	76	120	F185	F5•57, F5•63, F5•67, F5•69, F57, F63, F67, F69	285	60	76	120
F225	F5•71, F71	273	40	76	120	F225	F5•71, F71	319	80	76	120
	F7•75, F7•79, F75, F79	308	50	108.8	120		F7•75, F7•79, F75, F79	360	100	108.8	120
F265	F5•71, F71	279	40	76	120	F265	F5•71, F71	332	90	76	120
	F7•75, F7•79, F75, F79	314	60	108.8	120		F7•75, F7•79, F75, F79	363	100	108.8	120
F330	F7•75, F7•79, F75, F79	317	60	108.8	120	F330	F7•75, F7•79, F75, F79	364	100	108.8	120
F400	F7•75, F7•79, F7•81, F75, F79, F81	317	60	108.8	180	F400	F7•75, F7•79, F7•81, F75, F79, F81	364	100	108.8	180
F500	F7•75, F7•79, F7•81, F75, F79, F81	346	70	108.8	180	F500	F7•75, F7•79, F7•81, F75, F79, F81	390	110	108.8	180
F630, F800	F7•81, F81	510	110	108.8	180	F630, F800	F7•81, F81	509	120	108.8	180

TeSys™ D Combination Starter Dimensions

Table 18.195: Non-Combination Starter Dimensions [6]

Non-Combination Starters		Type 1										Type 12/3R	
Non-Reversing	Reversing	A	B	C	D	E	F	G	H	J	K	D	E
D09-32	—	6.77	10.04	6.25	5.38	9.00	1-1.25	0.5-0.75	—	1-0.25	0.5-0.75	5.38	11.37
D40-65	D09-32	8.66	10.83	7.21	7.25	9.75	1.25-1.5	0.5-0.75	1-1.25	1-0.25	0.5-0.75	5.38	12.15
D80	D40-80	10.63	13.98	7.21	9.22	12.94	1.25-1.5	0.5-0.75	1-1.25	1-1.25	0.5-0.75	5.38	15.30

Table 18.196: TeSys D Combination Starter Dimensions, Reversing and Non-Reversing

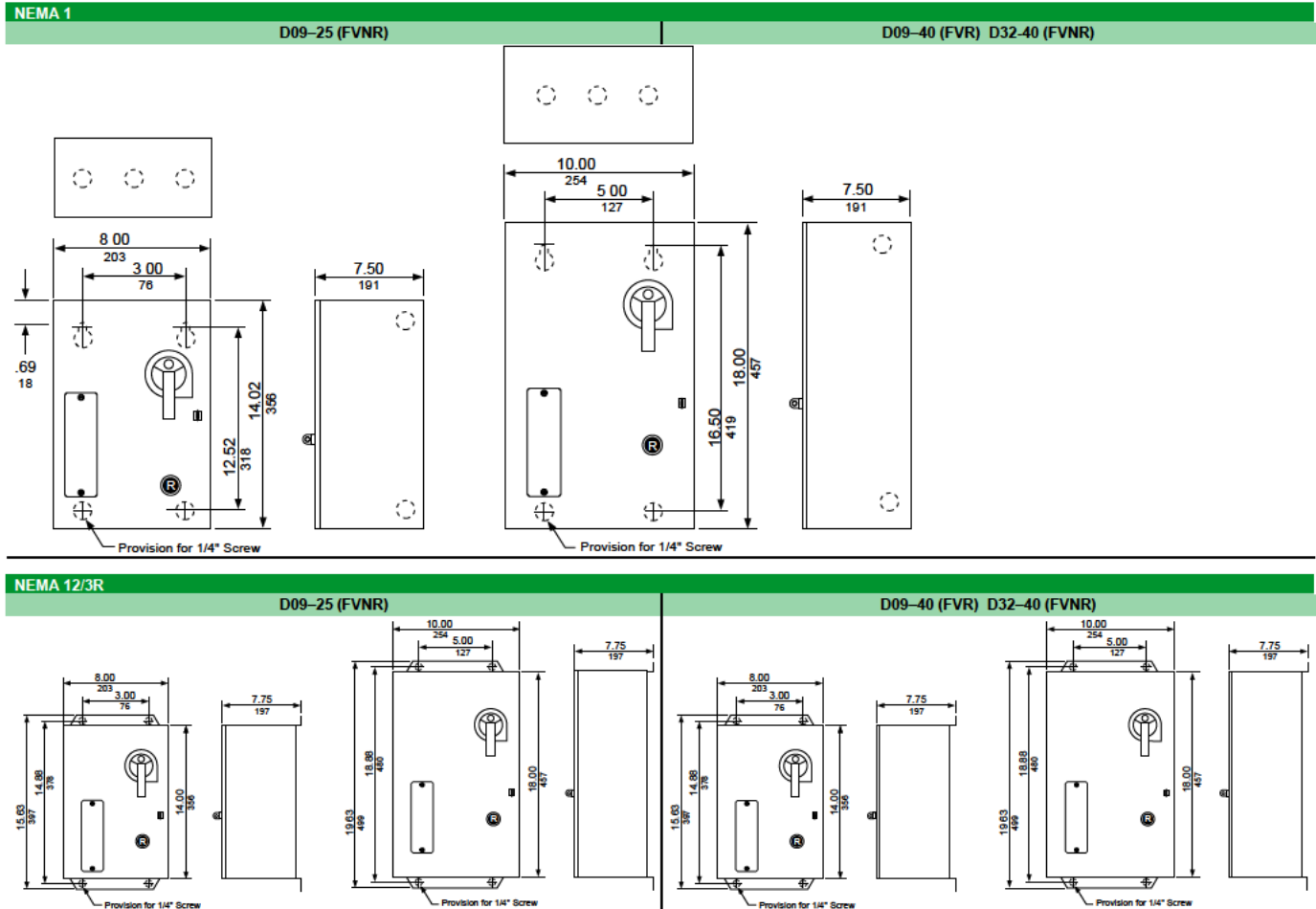

[6] All dimensions in inches.

TeSys™ K Contactor Dimensions

Table 18.197: TeSys K Contactor Dimensions

<p>LR2K Direct mounting under the contactor</p>	<p>Separate mounting with LA7-K0064 terminal block on 35 mm rail (AM1DP200 or AM1DE200)</p>
<p>Three-phase</p>	<p>Wiring Scheme</p>
<p>LC1, LP1, LP4K Mini-contactors On baseplate</p>	<p>LC2, LC8, LP2, LP5K Reversing mini-contactors On baseplate</p>
<p>On AM1DP200 or DE200 rail (35 mm)</p>	<p>On AM1DP200 or DE200 rail (35 mm)</p>
<p>On printed circuit board</p>	<p>On printed circuit board for reversing contactors or 2 mini-contactors side-by-side</p>
<p>LA2KT Electronic time delay contact blocks</p>	<p>On mini-contactors or reversing mini-contactors</p>

TeSys™ U Starter Dimensions

Table 18.198: TeSys U Starter Dimensions

Starter Controllers		Non-Reversing [7]		Reversing	
Rail Mounting		Screw Mounting		Screw Mounting	

NOTE Minimum electrical clearance:
X1: 35 mm for Ue = 440 V, and 70 mm for Ue = 500 and 690 V
X2: 0

Reversing Block for Mounting Separately from Power Base		
Rail Mounting	Screw Mounting	

Limiter Disconnecter LUALB1[7]	

Door interlock Mechanisms	
LU9APN43 and LU9APN44	

[7] Maximum depth (with Modbus™ communication module)

Altistart U01 and TeSys U Soft Starters, Mounting

Table 18.199: Altistart U01 and TeSys U Soft Starters

TeSys U Combination (non-reversing power base) and ATSU01N212LT Mounting on (35 mm) rail with VW3 G4104 connector	TeSys U Combination (non-reversing power base) and ATSU01N222LT to ATSU01N232LT Mounting on (35 mm) rail with VW3G4104 connector
--	---

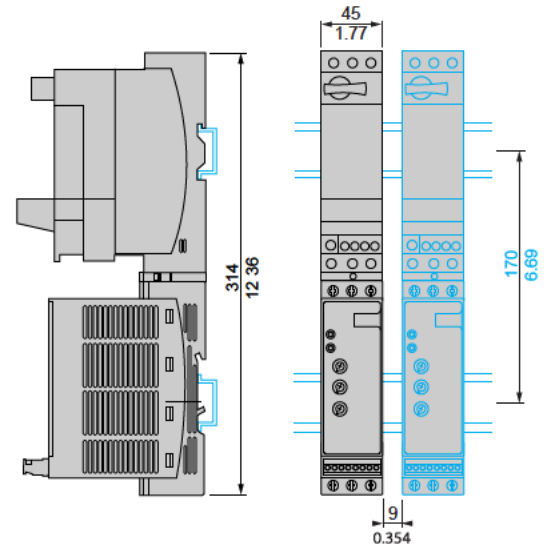
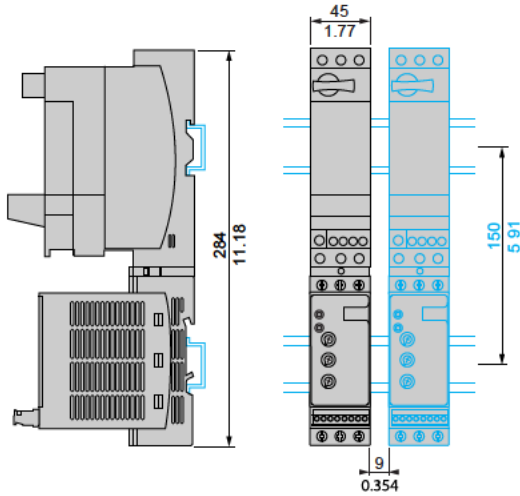

TeSys U Combination (non-reversing or reversing power base) and ATSU01N2206LT to ATSU01N212LT Side-by-side mounting
--

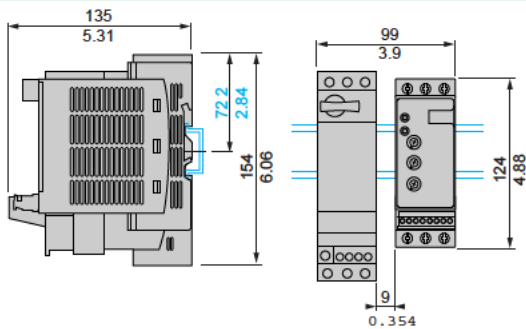

TeSys U Combination (non-reversing or reversing power base) and ATSU01N222LT to ATSU01N232LT Side-by-side mounting

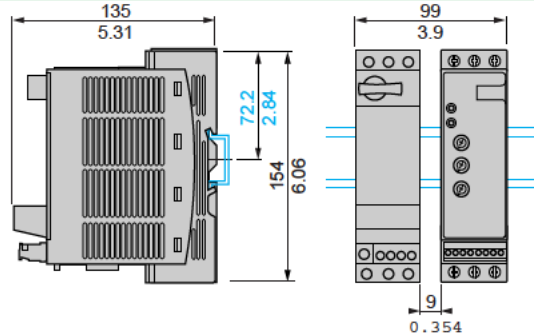

VW3G4104 Power Connector

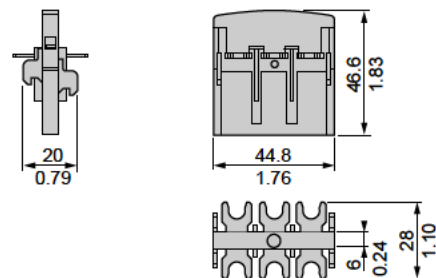

TeSys GV2 and GV3 Manual Starter and Protector Dimensions

Table 18.200: TeSys GV2 and GV3 Manual Starter and Protector Dimensions

GV2M	GV2AD, AM, AN, AU, AS, AX	GV2AE	Mounting of GV2M		
			On 35 mm L-rail C 78.5 mm (3.09") on AM1DP200 (35 x 7.5 mm) C 86 mm (3.39") on AM1DE200, ED200 (35 x 15 mm)		
GV2P	GV2AD, AM, AN, AU, AS, AX	GV2AK00	Mounting of GV2P		
			On 35 mm L-rail C 98.5 mm (3.88") on AM1DP200 (35 x 7.5 mm) C 106 mm (4.17") on AM1DE200, ED200 (35 x 15 mm)		
GV2AF4 + LAD31		GV2P + GV2GH7	GV2P + GV2GH7 + TeSys D contactor		
Combination GV2ME + TeSys D range contactor 	Combination GV2P + TeSys D range contactor 	for UL 508 Type E application 	for UL 508 Type E application 		
GV2ME +	LC2D09 to D18	LC2D25 and D32	GV2P +	LC2D09 to D18	LC2D25 and D32
b	7.4 (188.6)	7.8 (199)	b	6.61 (168.1)	7.9 (199.5)
c1	3.6 (92.7)	3.9 (99)	c1	4.6 (116.8)	4.6 (116.8)
c	3.9 (98.2)	4.11 (104.5)	c	4.8 (122.3)	4.8 (122.3)
d1	3.9 (98.3)	3.9 (98.3)	—	—	—
d	4.1 (103.8)	1.4 (103.8)	—	—	—
Surface mounting enclosure GV2MC0•			Flush mounting enclosure GV2MP0• (bracket cut-out)		
4 knock-outs for 16 mm plastic cable glands or no. 16 conduit. 					

GV2	b		b1	
	in.	mm	in.	mm
MP01, MP02	5.51	140	5.00	127
MP03, MP04	5.24	133	4.61	117

Table 18.201: TeSys GV2 and GV3 Manual Starter and Protector Dimensions (cont'd)

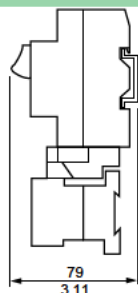
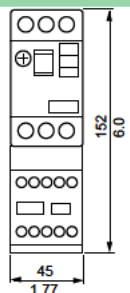
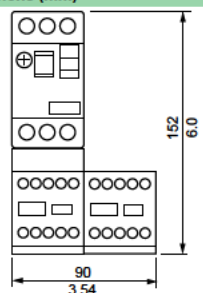
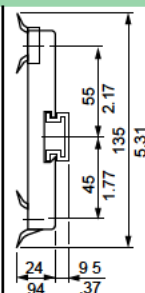
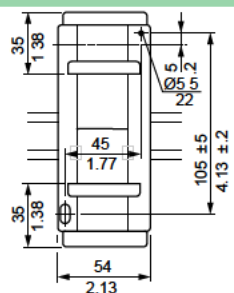
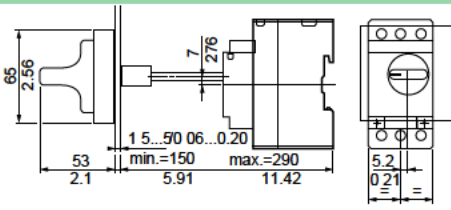
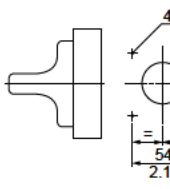
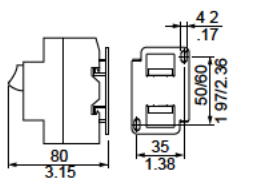
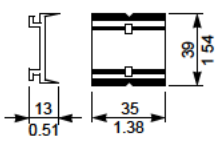
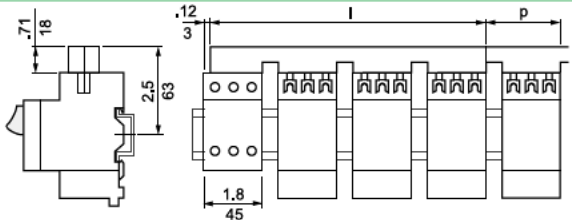
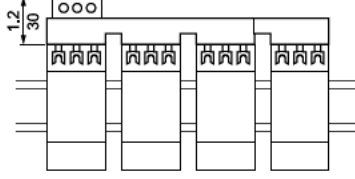
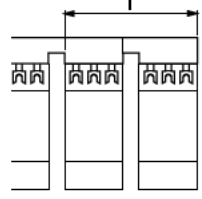
GV2M with GK2AF01 and LC1K	GV2M with GV2AF01 and LC1K	GV2M with GV2AF01 and LC2K		Adapter Plate GK2AF01																						
Dimensions (mm)																										
																										
Mounting external operator GV2AP0●	Door cut-out	GV2M on panel with GV2AF02 adapter plate	7.5 mm height compensation plate GV1F03																							
																										
Sets of bus bars, GV2G445, GV2G454, GV2G472 with terminal block GV2G05		Sets of bus bars with terminal block GV1G09	Sets of bus bars GV2G245, GV2G254, GV2G272																							
																										
	<table border="1"> <thead> <tr> <th></th> <th>I</th> <th>P</th> </tr> </thead> <tbody> <tr> <td>GV2G445</td> <td>0.16 x 1.8 in. (4 x 45 mm)</td> <td>7.0 in. (179 mm)</td> </tr> <tr> <td>GV2G454</td> <td>0.16 x 2.1 in. (4 x 54 mm)</td> <td>8.1 in. (206 mm)</td> </tr> <tr> <td>GV2G472</td> <td>0.16 x 1.8 in. (4 x 45 mm)</td> <td>10.2 in. (260 mm)</td> </tr> </tbody> </table>		I	P	GV2G445	0.16 x 1.8 in. (4 x 45 mm)	7.0 in. (179 mm)	GV2G454	0.16 x 2.1 in. (4 x 54 mm)	8.1 in. (206 mm)	GV2G472	0.16 x 1.8 in. (4 x 45 mm)	10.2 in. (260 mm)	<table border="1"> <thead> <tr> <th></th> <th>I</th> </tr> </thead> <tbody> <tr> <td>GV2G245</td> <td>0.08 x 1.8 in. (2 x 45 mm)</td> </tr> <tr> <td>GV2G254</td> <td>0.08 x 2.1 in. (2 x 54 mm)</td> </tr> <tr> <td>GV2G272</td> <td>0.08 x 2.8 in. (2 x 72 mm)</td> </tr> <tr> <td>GV2G354</td> <td>0.12 x 2.1 in. (3 x 54 mm)</td> </tr> </tbody> </table>		I	GV2G245	0.08 x 1.8 in. (2 x 45 mm)	GV2G254	0.08 x 2.1 in. (2 x 54 mm)	GV2G272	0.08 x 2.8 in. (2 x 72 mm)	GV2G354	0.12 x 2.1 in. (3 x 54 mm)		
	I	P																								
GV2G445	0.16 x 1.8 in. (4 x 45 mm)	7.0 in. (179 mm)																								
GV2G454	0.16 x 2.1 in. (4 x 54 mm)	8.1 in. (206 mm)																								
GV2G472	0.16 x 1.8 in. (4 x 45 mm)	10.2 in. (260 mm)																								
	I																									
GV2G245	0.08 x 1.8 in. (2 x 45 mm)																									
GV2G254	0.08 x 2.1 in. (2 x 54 mm)																									
GV2G272	0.08 x 2.8 in. (2 x 72 mm)																									
GV2G354	0.12 x 2.1 in. (3 x 54 mm)																									

GV3P Dimension Mounting on rail AM1 DE200 or AM1 ED201

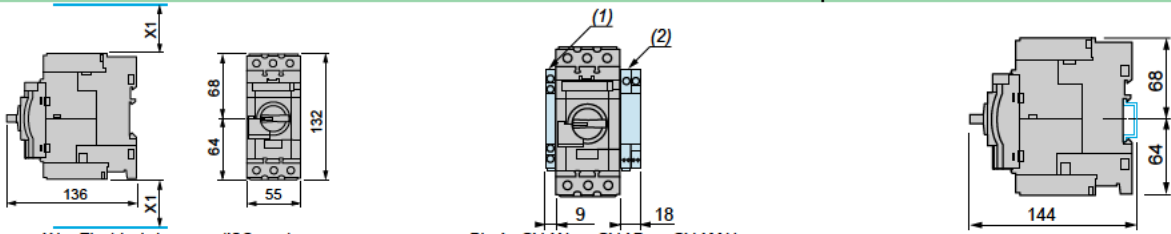

X1 = Electrical clearance (ISC max)
40 mm for Ue < 500 V; 50 mm for Ue < 690 V

Blocks GV AN●●, GV AD●●, GV AM11
Block GV3 AU●● and GV3 AS●●

Mounting on panel, using M4 screws **Mounting on pre-slotted mounting plate AM1PA**

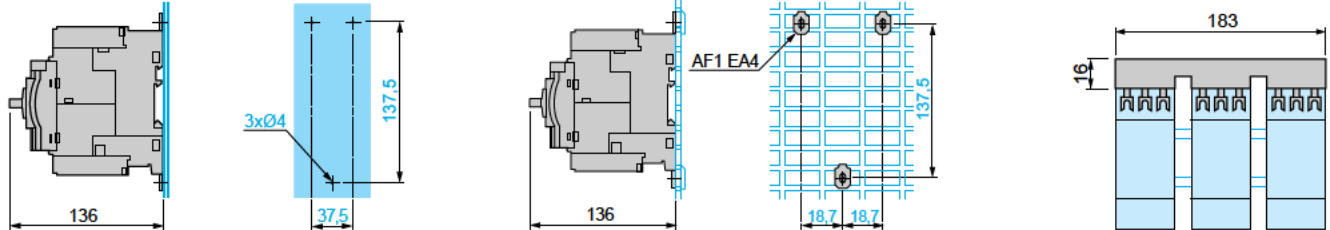

NOTE Leave a space of 9 mm between 2 manual motor protectors: either an empty space or side-mounting add-on contact blocks.
Horizontal mounting is possible: please consult your regional sales office.

TeSys GV7 Manual Starter and Protector Dimensions

Table 18.202: TeSys GV7 Manual Starter and Protector Dimensions

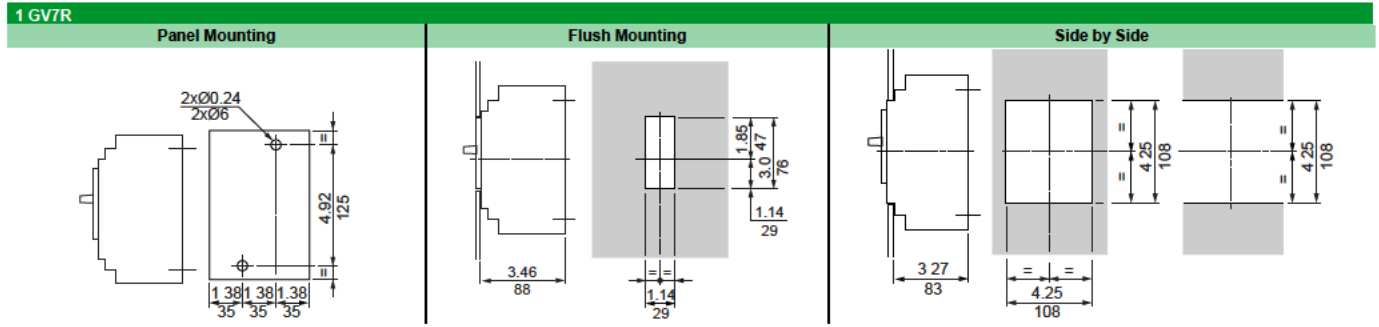

Minimum Clearance	x1		x2
	in. (mm)		
Painted or insulated metal plate, insulation or insulated bar	U < 440 V		0 (0)
	440 V < U < 600 V		1.38 (35)
	U > 600 V		1.38 (35)
Bare metal plate	U < 440 V		0.79 (20)
	440 V < U < 600 V		1.38 (35)

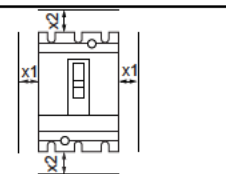

NOTE Minimum distance between 2 units mounted side by side = 0.

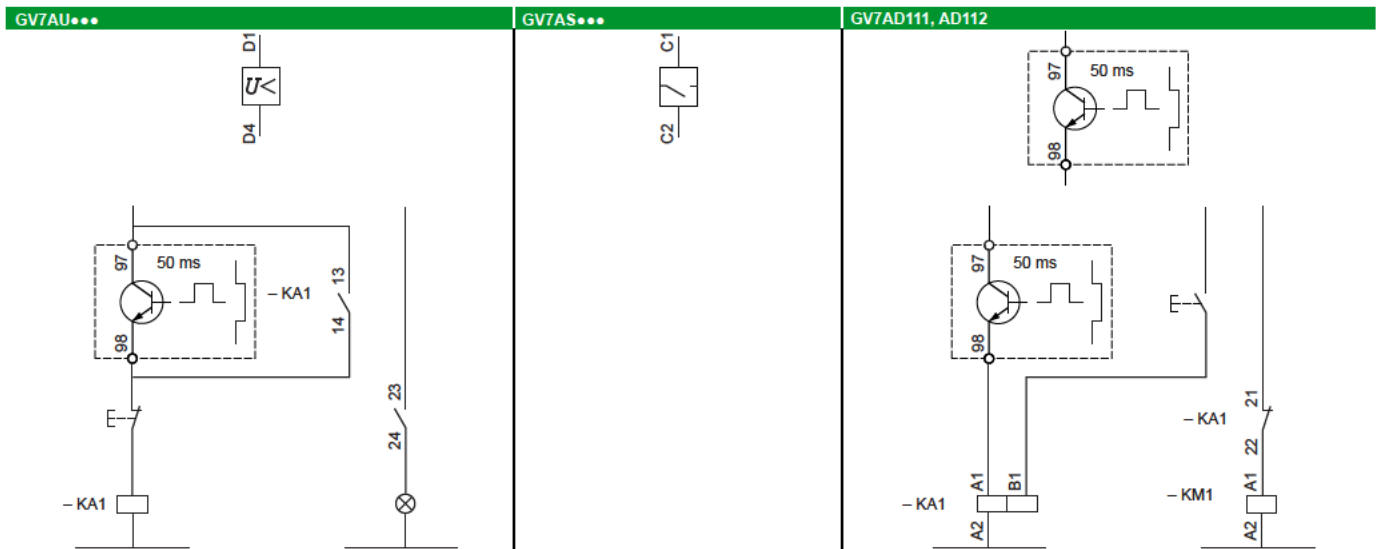
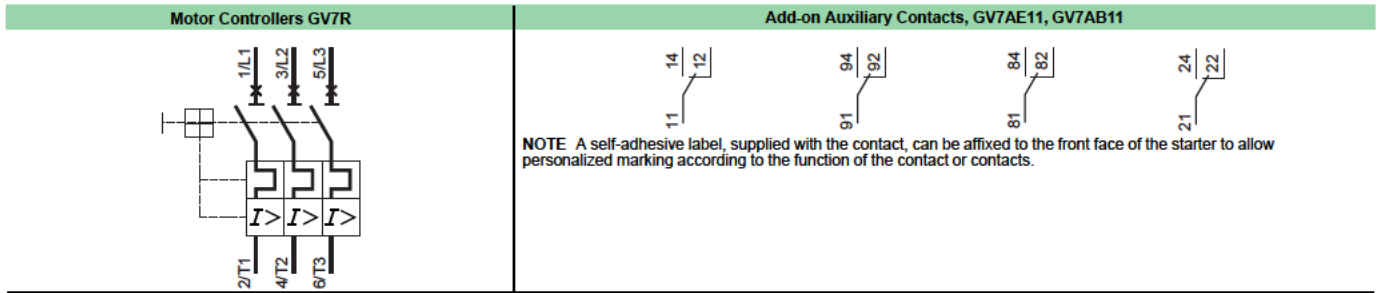

GV7AC03

Spreaders

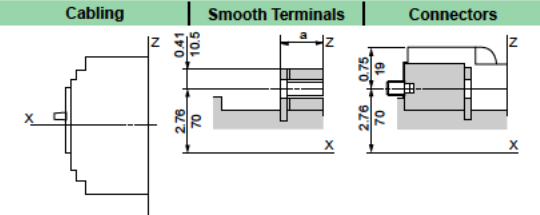
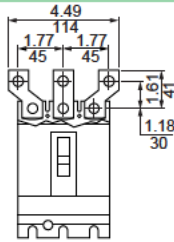

	a (in./mm)
GV7R●	0.77/19.5
GV7R●220	0.85/21.5

GV7AP03, GV7A04

Direct Rotary Handle

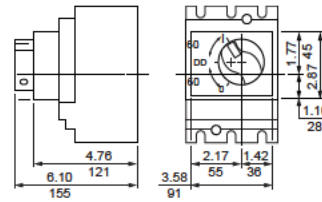

Flush Mounting

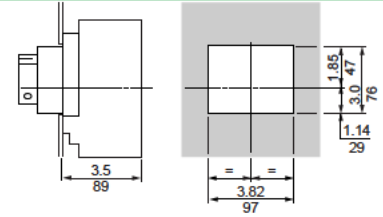

GV7AP03 or GV7AP04, GV7AP05

Direct Rotary Handle

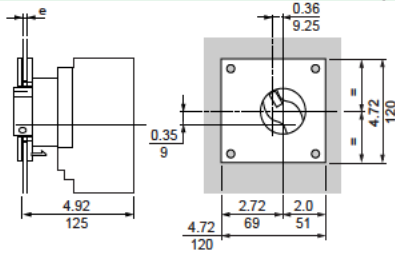

Front Fuse Center

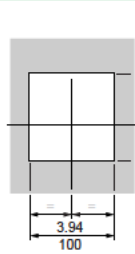

Enclosure Viewed from Top

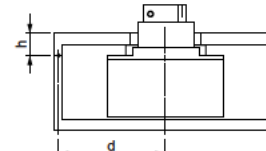

Door cutouts require a minimum distance between the center of the manual motor protector and the door hinge point (h) of $d \geq 3.94$ in (100 mm) + (h x 5)

GV7AP01, GV7AP02

Extended Rotary Handle

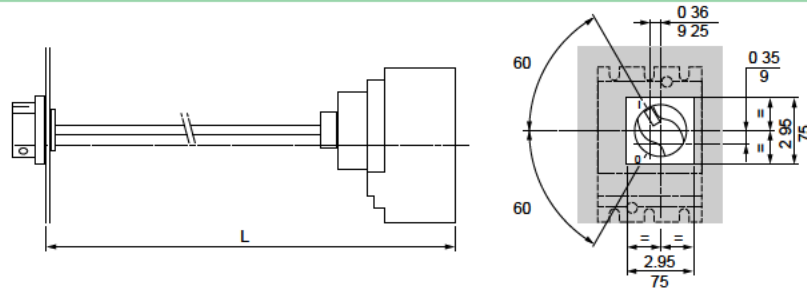

L: 7.28 in. (185 mm) minimum, 23.62 in. (600 mm) maximum.
The shaft of the extended rotary handle GV7AP01 or GV7AP02 must be cut to length: L – 4.96 in. (126 mm)